



USER MANUAL

AX12C

High Output Column Array

KEY FEATURES

- High Power passive portable Line Array element
- Designed for mobile and installed applications
- Fast, easy-to-use integrated suspension system
- Aluminium frame structure
- Black or white finish
- 12 x 3.5" neodymium transducers with waterproof cones
- Acoustic transmission line back loading design, resulting in clean mid-bass reproduction and natural cardioid behaviour
- Wide horizontal dispersion through Front Diffraction Waveguide (FDW)
- Line Array dispersion characteristics

INTRODUCTION

The AX12C Line Array is a passive system equipped with twelve 3.5" neodymium transducers with waterproof cones, designed for portable and permanently installed applications where high power and clarity are needed. The aluminum frame box structure ensures lightweight and strength, while the shape features a back-loaded transmission line design with clean mid-bass reproduction and natural cardioid behaviour. A Front Diffraction Waveguide (FDW) delivers wide horizontal dispersion, making the system flexible and adaptable to many different applications.

The AX12C line array module has been designed to be combined with the SW2100A, a compact and lightweight 21" and-Pass/Bass-Reflex subwoofer, equipped with a 4000W Class D amplifier with Power Factor Correction and PROEL's proprietary 96kHz / 40bit floating point CORE DSP. Up to four AX12C modules can be driven by one amplifier channel of the SW2100A subwoofer. The built-in CORE DSP, which can be also remotely controlled using PRONET AX software, provides 4 presets for different combinations: 2, 4 or 1 columns plus 1 user preset.

The standard system, composed of four AX12C line array modules and two SW2100A subwoofers, features 8000W of total power and a line-array dispersion pattern, making it the perfect solution for high-performance portable sound reinforcement applications.

Thanks to the elegant mechanical design the AX12C can be easily transported, while the integrated suspension system makes its deployment very fast and simple. Each unit comes with two aluminum brackets and four pins that allows multiple array elements to be easily combined either together or with the matching SW2100A subwoofer, or also in combination with the complete range of mounting hardware available, including flybar and several brackets and stands.

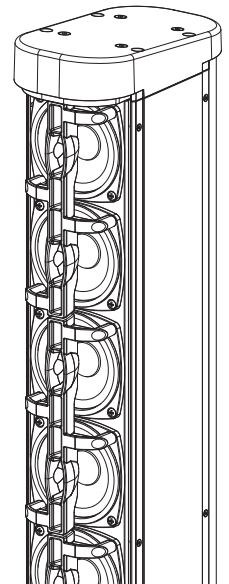

TECHNICAL SPECIFICATION

| SYSTEM | | INPUT CONNECTIONS | |
|-----------------------------|--|-------------------------------------|---|
| System's Acoustic Principle | Line Array Element Short Transmission Line Back Loading Front Diffraction Waveguide | Connector Type | Neutrik® Speakon® NL4 x 2 (1+/1- signal IN & LINK ; 2+/2- thru) |
| Frequency Response (±3dB) | 180 Hz - 16 KHz (Processed) | POWER HANDLING | |
| Nominal Impedance | 16 Ohm | Continuous AES Pink Noise Power | 360 W |
| Minimum Impedance | 12.5 Ohm | Program Power | 720 W |
| Horizontal Coverage Angle | 100° (-6 dB) | ENCLOSURE & CONSTRUCTION | |
| Sensitivity (4V) | 105 dB SPL @ 1m* | Width | 107 mm (4.2") |
| Maximum (peak) SPL | 130 dB SPL @ 1m* | Height | 1166 mm (45.9") - without flying system 1212 mm (47.7") - with flying system |
| TRANSDUCERS | | Depth | 193 mm (7.6") |
| Type | 12 x 3.5" (88mm) Neodymium magnet woofers, 1" (25mm) VC | Enclosure Material | Aluminum |
| Cone | Waterproof Cone | Paint | High resistance, water based paint, black or white finish |
| Voice Coil Type | Ventilated voice coil | Flying system | Aluminum Fast Link structure with dedicated pins |
| | | Net Weight | 10.9 kg / 24.0 lbs. (without flying system) 13 kg / 28.6 lbs. (with flying system) |

*measured @4 m and scaled @1 m





MECHANICAL DRAWING

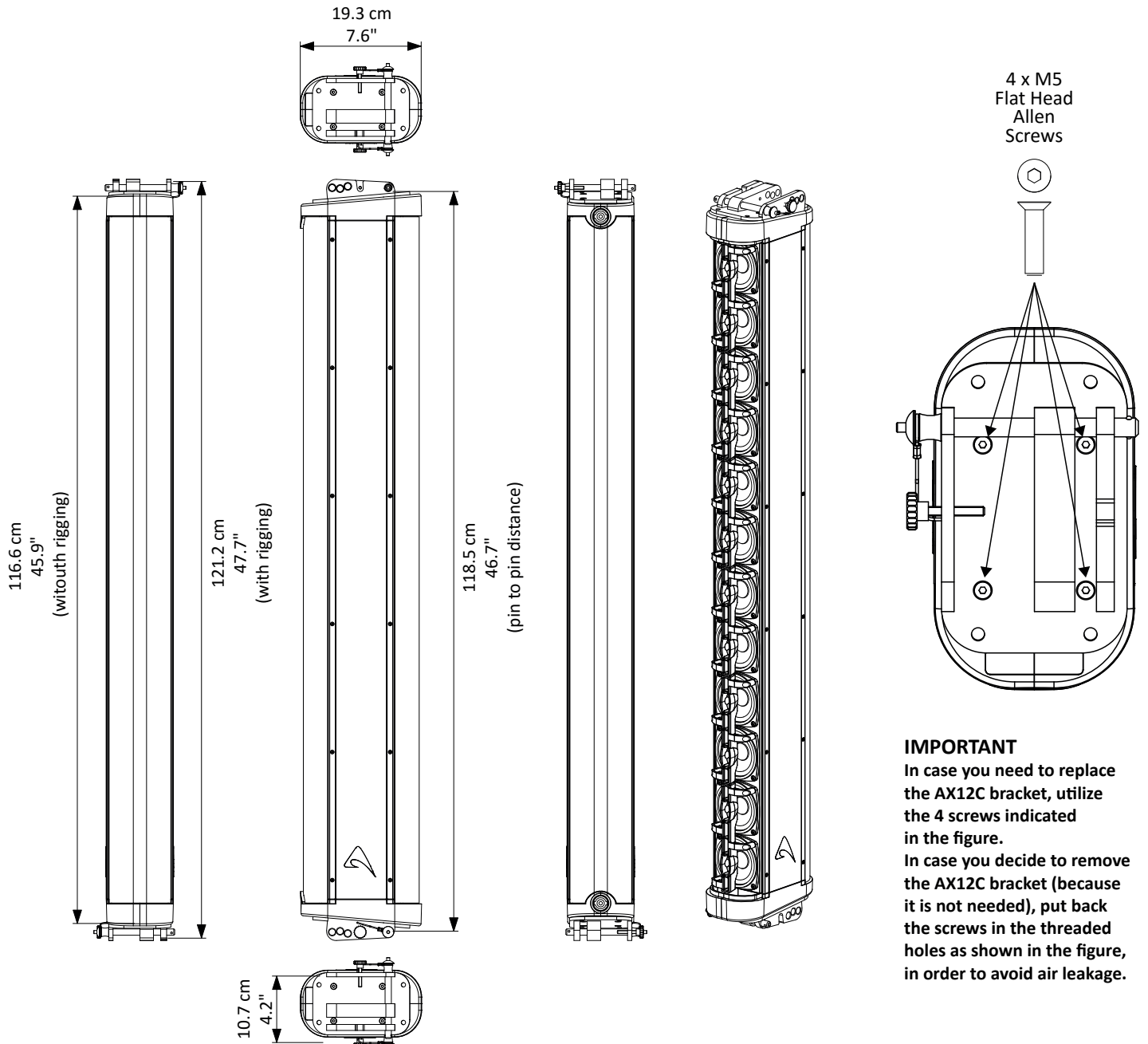

IMPORTANT
 In case you need to replace the AX12C bracket, utilize the 4 screws indicated in the figure.
 In case you decide to remove the AX12C bracket (because it is not needed), put back the screws in the threaded holes as shown in the figure, in order to avoid air leakage.

OPTIONAL ACCESSORIES

| | | | |
|---------------------|--|---------------------|---|
| COVERAX12C | Cover / carry bag for single AX12C/AX12LF | KPTFAX12C | Floor stand |
| AXCASE09 | Flight case for two AX12C/AX12LF and accessories | KPTPOLEAX12C | Pole adapter |
| AXCASE10 | Flight case for four AX12C/AX12LF and accessories | DHSS10M20 | Sub-Speaker ø35mm 1-1.7m Pole with Handle and M20 screw |
| ESO2500LU025 | 25 cm SPEAKON linking cable 4x4mm | KP210S | Sub-Speaker ø35mm 0.7-1.2m Pole with M20 screw |
| NL4FX | Neutrik Speakon® PLUG | KPTAX12C | Flybar for suspending up to 4 units |
| KPTWAX12C | Wall bracket for up to 2 units | PLG716 | Straight Shackle 16 mm for Fly bar |
| KPTFAXC | Foam adapters for stage monitor or frontfill application | | |

see <http://www.axiomproaudio.com> for detailed description and other available accessories.

SPARE PARTS

| | | | |
|-------------------|-------------------------------|----------------------|--------------------------------------|
| NL4MP | Neutrik Speakon® panel socket | 95MET300023 | AX12C front speaker net colour black |
| 94SPI10100 | Locking Pin for AX12C | 95MET300024 | AX12C rear speaker net colour black |
| 98TDS3W222 | 3.5" speaker - 1" VC - 22 ohm | 95MET300023WH | AX12C front speaker net colour white |
| | | 95MET300024WH | AX12C rear speaker net colour white |





REAR PANEL

INPUT & LINK - Both connectors at the top and the bottom of the AX12C can operate as input or link, to connect an appropriated processed amplifier or to link the column to a second one.

The AX12C does not include an internal passive crossover for filtering the signal, but only an internal protection that excludes the internal speaker to protect them from excessive input power. The protection should not trip with a typical music program, but only with a massive and constant power signal, like a feedback. The connections are the following:

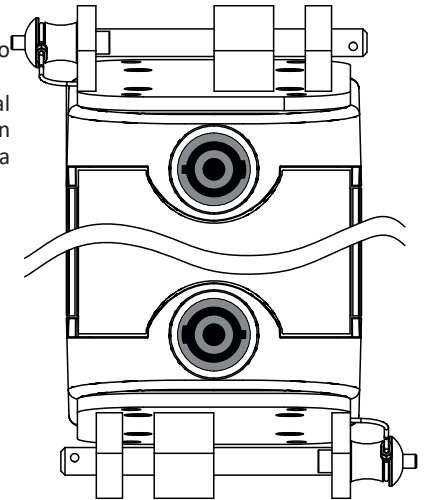

| INPUT - LINK | |
|----------------|--|
| NL4 pin number | internal connection |
| 1+ | + speakers (pass thru link speakon) |
| 1- | - speakers (pass thru link speakon) |
| 2+ | + no connection (pass thru link speakon) |
| 2- | - no connection (pass thru link speakon) |

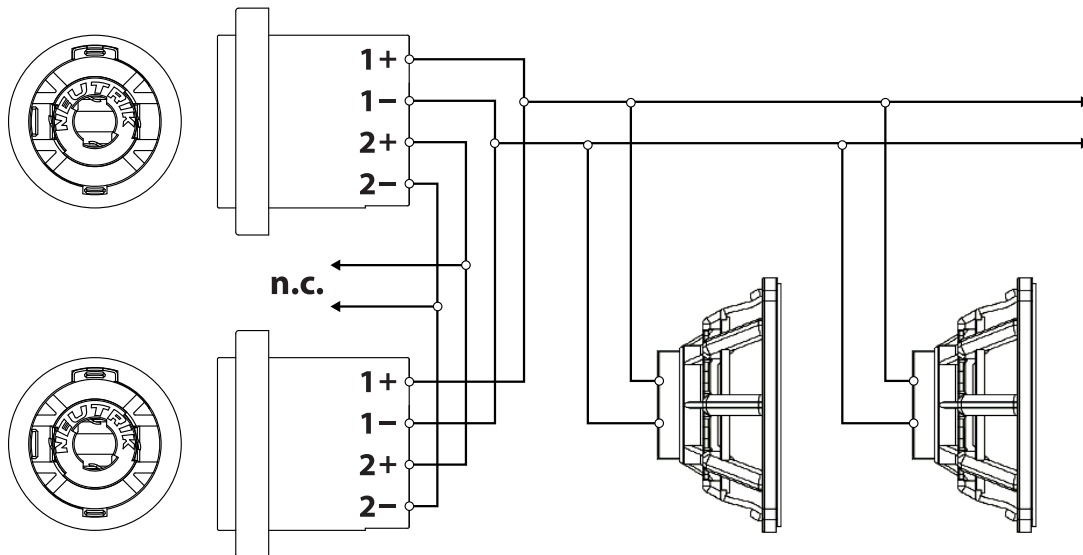

WARNING: the maximum quantity of AX12C that can be linked together depends by the load capacity of the appropriate processed amplifier. When powered from the SW2100A subwoofer or from the QC2.4 suggested amplifier, a maximum of four AX12C can be connected to each power output.

TOOLS

This is a list of tools that can be useful to set properly a vertical column array system.

CABLE TESTER

It is a good practice to check all cables before each installation, because even one faulty cable can compromise heavily the system performance.

INCLINOMETER WITH LEVER

This tool can be used to verify the vertical array angle. It can be used at the top or at the bottom of the array. In this case you have to sum all splay angles, so the maximum precision is needed for aiming the vertical array, particularly for long throw applications.

LASER DISTANCE METER

This instrument can be useful to measure the height of the vertical array and to know the distance between FOH-Subs and FOH-Array for setting the delay time.

ACOUSTIC MEASUREMENT SYSTEM (SMAART, SATlive or similar)

These are useful to measure delays, phase and response of the system.





PREDICTION: EASE Focus 3

To aim correctly a complete system we suggest to use always the Aiming Software - EASE Focus 3.

The EASE Focus 3 Aiming Software is a 3D Acoustic Modelling Software that serves for the configuration and modelling of Line Arrays and conventional speakers close to reality. It only considers the direct field, created by the complex addition of the sound contributions of the individual loudspeakers or array components.

The design of EASE Focus is targeted at the end user. It allows the easy and quick prediction of the array performance in a given venue. The scientific base of EASE Focus stems from EASE, the professional electro and room acoustic simulation software developed by AFMG Technologies GmbH. It is based on the EASE GLL loudspeaker data file required for its use: **AXIOM_Column_vX_X**. The GLL file contains the data that defines the Line Array with regard to its possible configurations as well as to its geometrical and acoustical properties.

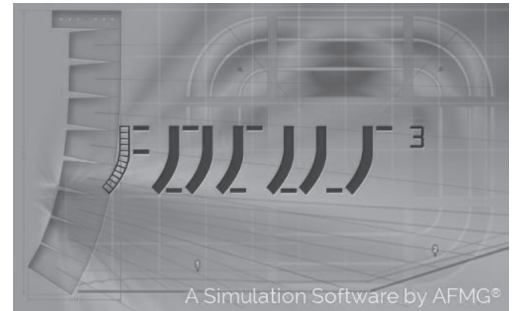

Download the EASE Focus 3 app from the AXIOM website at <http://www.axiomproaudio.com/> clicking on downloads section of the product.

Use the menu option **Edit / Import System Definition File** to import the file **AXIOM_Column_vX_X** from the installation Data folder, the detailed instructions to use the program are located in the menu option **Help / User's Guide**.

Note: Some windows system can require the **.NET Framework 4** that can be download from microsoft website at <http://www.microsoft.com/en-us/download/default.aspx>.



WARNING! CAREFULLY READ THE FOLLOWING INSTRUCTIONS AND CONDITION OF USE:

- This loudspeaker is designed exclusively for Professional audio applications. **The product must be installed by qualified personal only.**
- Proel strongly recommends that this loudspeaker cabinet be suspended taking into consideration all current National, Federal, State and Local regulations. Please contact the manufacturer for further information.
- Proel do not accept any liability for damage caused to third parties due to improper installation, lack of maintenance, tampering or improper use of this product, including disregard of acceptable and applicable safety standards.
- During assembly pay attention to the possible risk of crushing. Wear suitable protective clothing. Observe all instructions given on the rigging components and the loudspeaker cabinets. When chain hoists are in operation ensure that there is nobody directly underneath or in the vicinity of the load. Do not under any circumstances climb on the array.

Pin locking and splay angles set up

The figure below shows how to insert correctly the locking pin and how to set up the splay angle between loudspeakers.

LOCKING PIN INSERTION

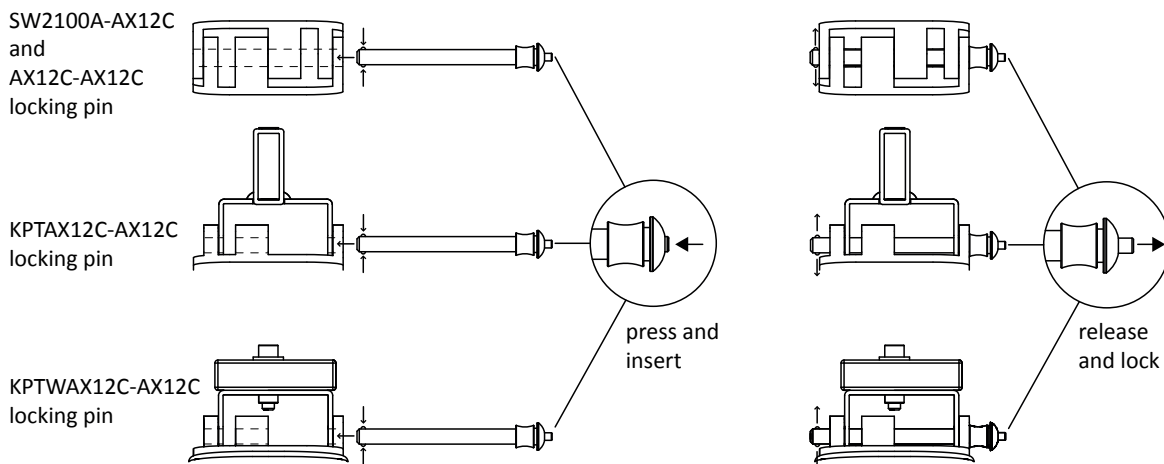

AX12C SPLAY ANGLE SET UP

When connecting two speakers together or one speaker to an installation accessory, insert the pin in this hole first, also use it to rest the pin when unused.

Use these holes for the splay angle:

- 0°** as no splay.
- 2°** as normal splay angle to obtain a curved vertical array.
- 4°** as splay angle to aim the first speaker downward (stacked only).

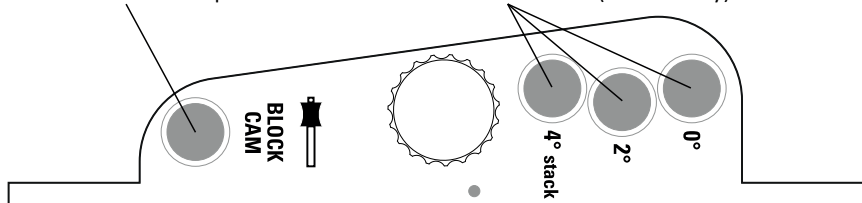



BASIC INSTALLATION INSTRUCTIONS

Stacked installation using SW2100A subwoofer as base

WARNING!



- The ground where the SW2100A is placed needs to be absolutely stable and compact.
- Adjust the feet so to put the SW2100A perfectly horizontal to ground. Use a spirit level to obtain the best results.
- Always secure ground stacked setups against movement and possible tipping over.
- A maximum of 2x AX12C or 4x AX6C or 1x AX12C + 1x AX6C speakers are allowed to be installed over a SW2100A serving as ground support.
- The optimal splay angles can be simulated using the EASE Focus 3 software.

TWO AX12C STACKED ON A SW2100A



WARNING: DO NOT STACK MORE THAN TWO AX12C UNITS.

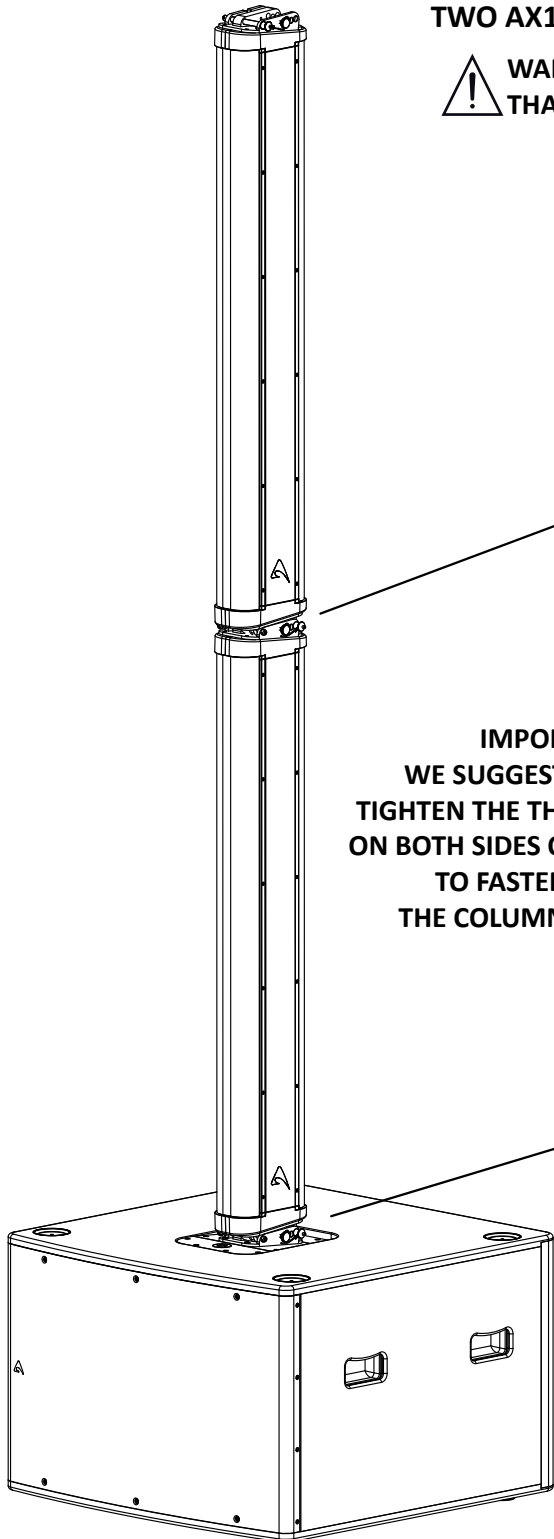

**IMPORTANT:
WE SUGGEST TO ALWAYS
TIGHTEN THE THREADED KNOBS *
ON BOTH SIDES OF THE BRACKETS
TO FASTEN TIGHTLY
THE COLUMNS TOGETHER**

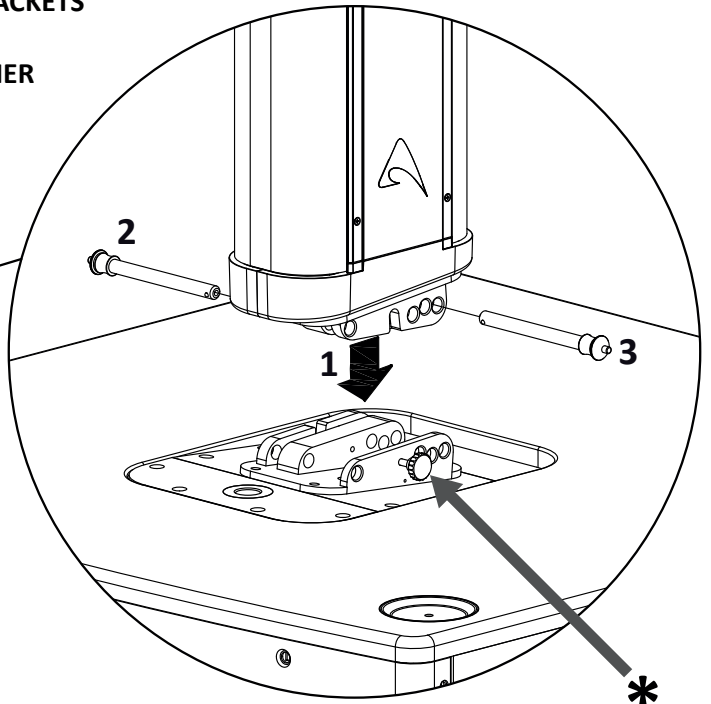
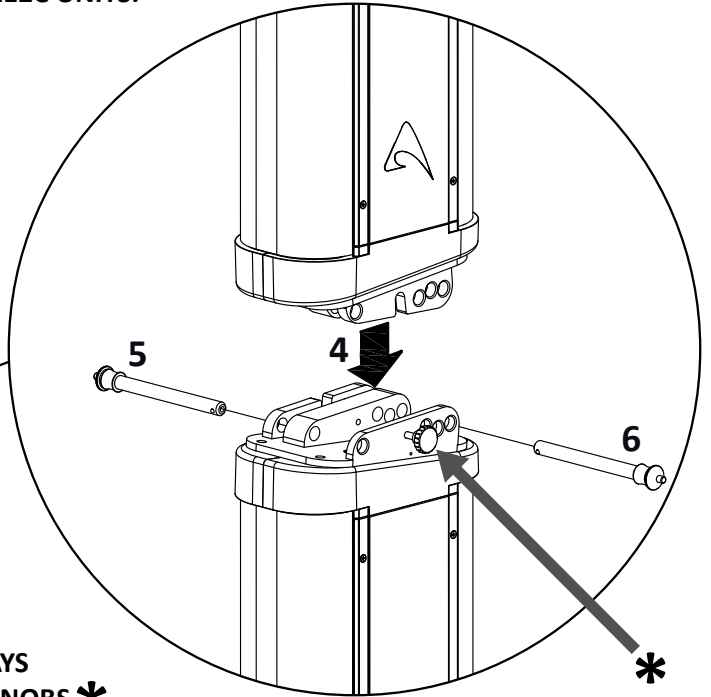



AIMING OPTIONS OF TWO AX12C MOUNTED ON A SW2100A

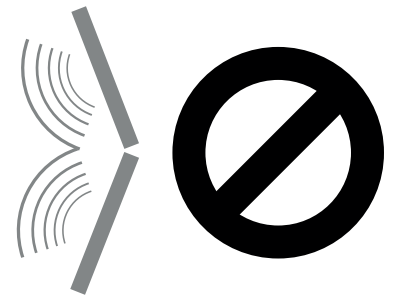
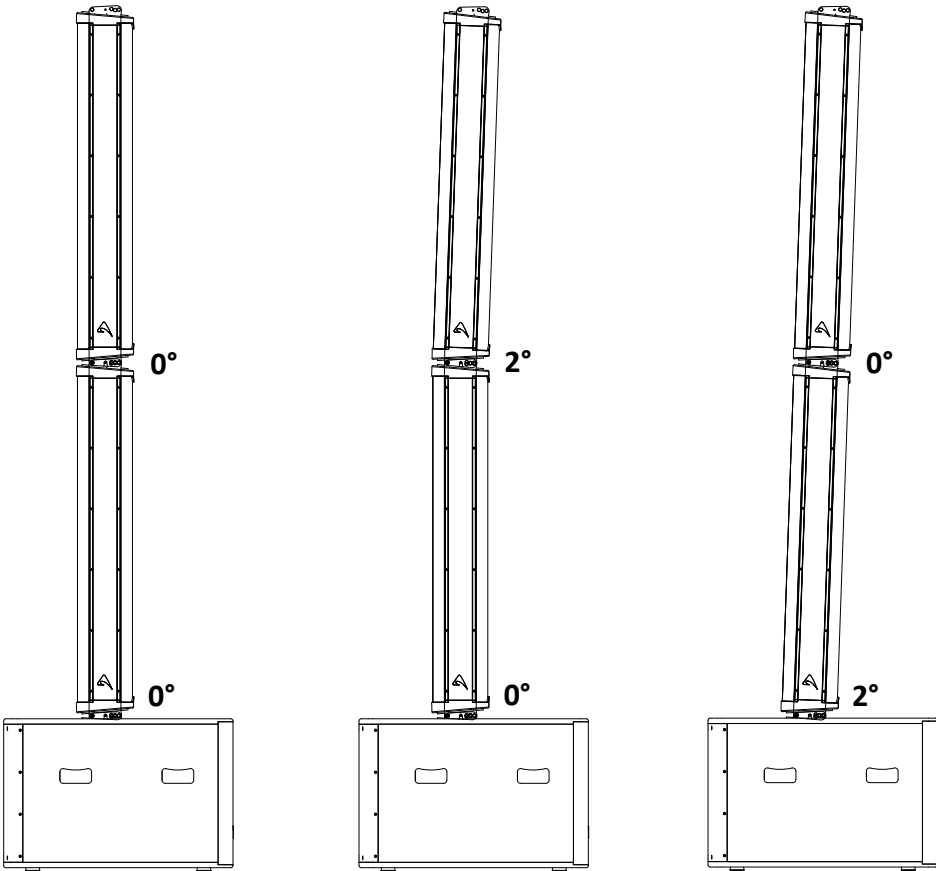

IMPORTANT:
NEVER INSTALL
2 OR MORE AX12C
AIMING THE SPEAKERS
TO EACH OTHER
WITH CLOSED ANGLES.
In other words, NEVER use
the 4° STACK position
between two speakers.

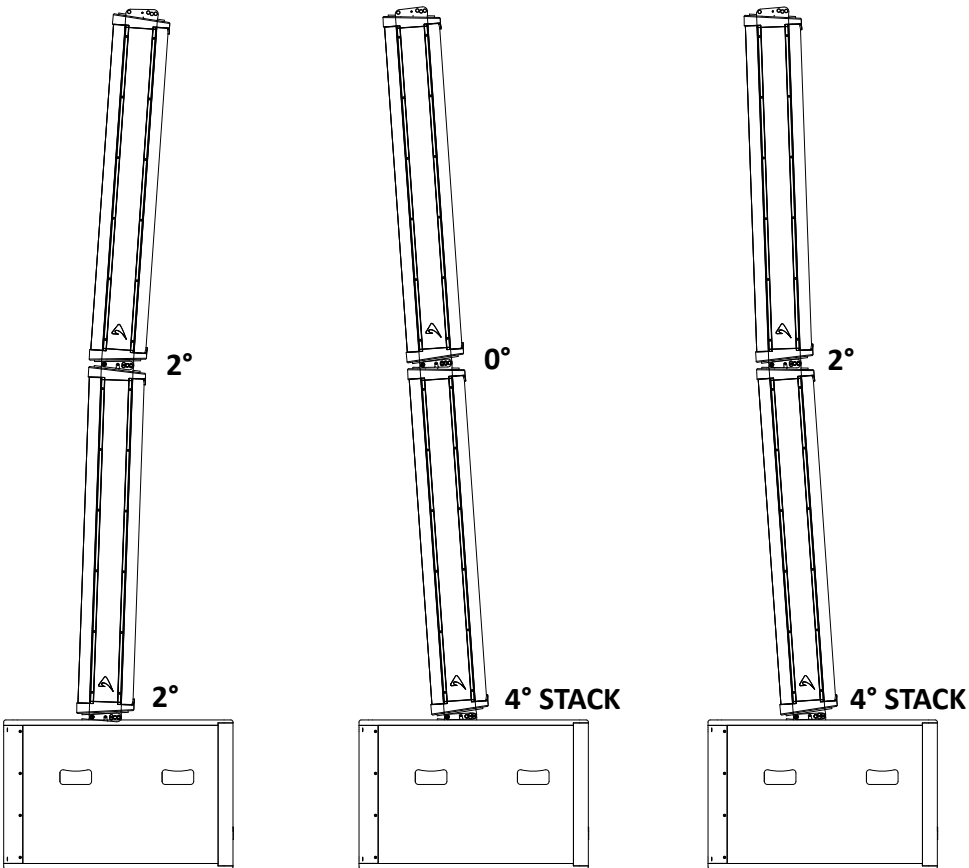



Stacked installation using KPTFAX12C floor stand

- WARNING!**
- The ground where the KPTFAX12C floor stand is placed needs to be absolutely stable and compact.
 - Adjust the feet so to put the KPTFAX12C perfectly horizontal to ground. Use a spirit level to obtain the best result.
 - Always secure ground stacked setups against movement and possible tipping over.
 - A maximum of 2 x AX12C speakers are allowed to be installed over a KPTFAX12C serving as ground support.
 - A maximum of 1 x AX12C cabinet is allowed to be installed over a pole.
 - The optimal splay angles can be simulated using the EASE Focus 3 software.

AX12C STACKED USING KPTFAX12C FLOOR STAND

WARNING: DO NOT STACK MORE THAN TWO AX12C UNITS ON FLOOR STAND SET THE ANGLE ONLY TO 0° OR 2°

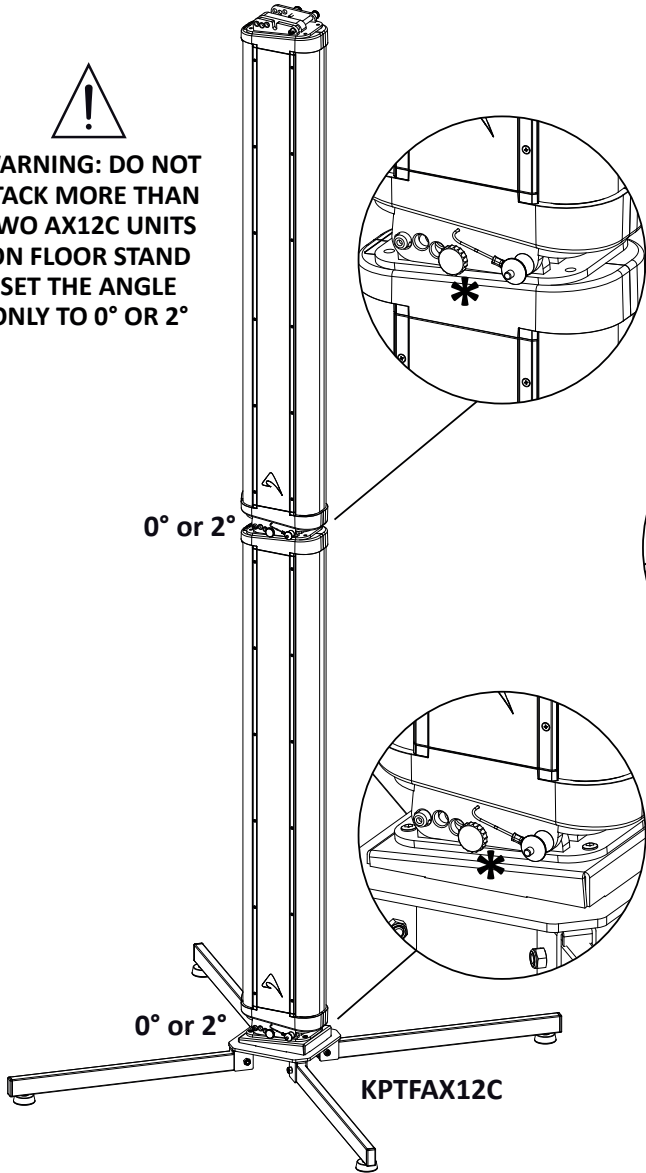

IMPORTANT: TIGHTEN THE THREADED KNOB * ON BOTH SIDES TO FASTEN THE BRACKETS TOGETHER

WARNING: DO NOT INSTALL MORE THAN ONE AX12C UNIT ON POLE SET THE ANGLE ONLY TO 0°

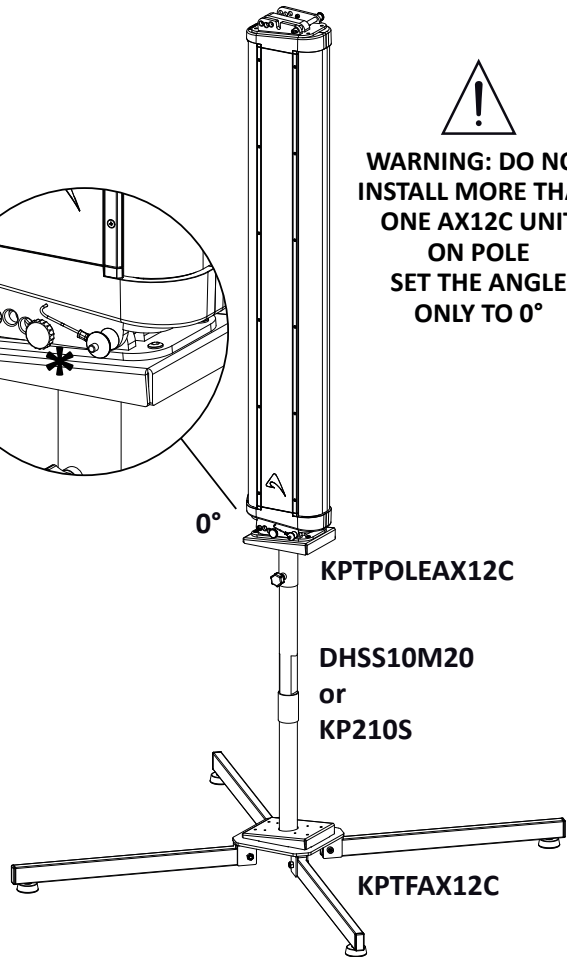

IMPORTANT: NEVER INSTALL 2 OR MORE AX12C AIMING THE SPEAKERS TO EACH OTHER WITH CLOSED ANGLES. In other words, NEVER use the 4° STACK position between two speakers.





Installation using KPTWAX12C wall bracket



WARNING!

- No hardware is supplied to install the KPTWAX12C to the walls, this hardware depends on the wall structure. Use always the best hardware available taking in consideration the whole weight of loudspeakers and accessories.
- Brackets **MUST** be installed by qualified personnel in accordance with safe installation practices.
- A maximum of 2 x AX12C speakers can be installed using the KPTWAX12C wall bracket.
- The optimal splay angles can be simulated using the EASE Focus 3 software.

KPTWAX12C AIMING OPTIONS

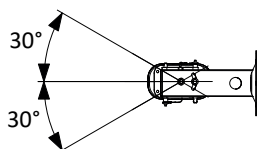
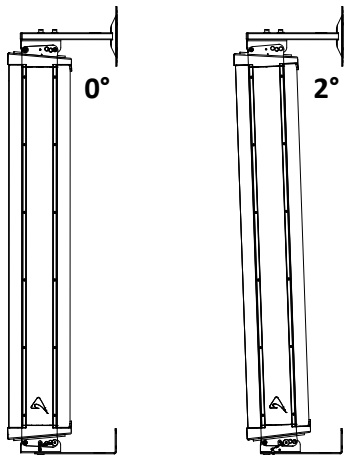
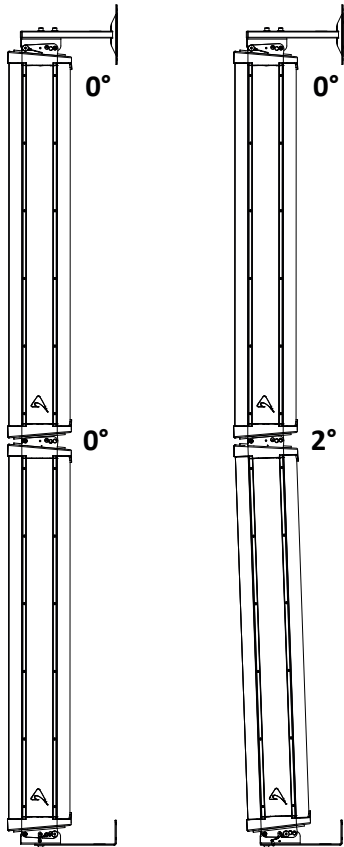

KPTWAX12C MOUNTING OPERATIONS



WARNING: DO NOT INSTALL MORE THAN TWO AX12C UNITS

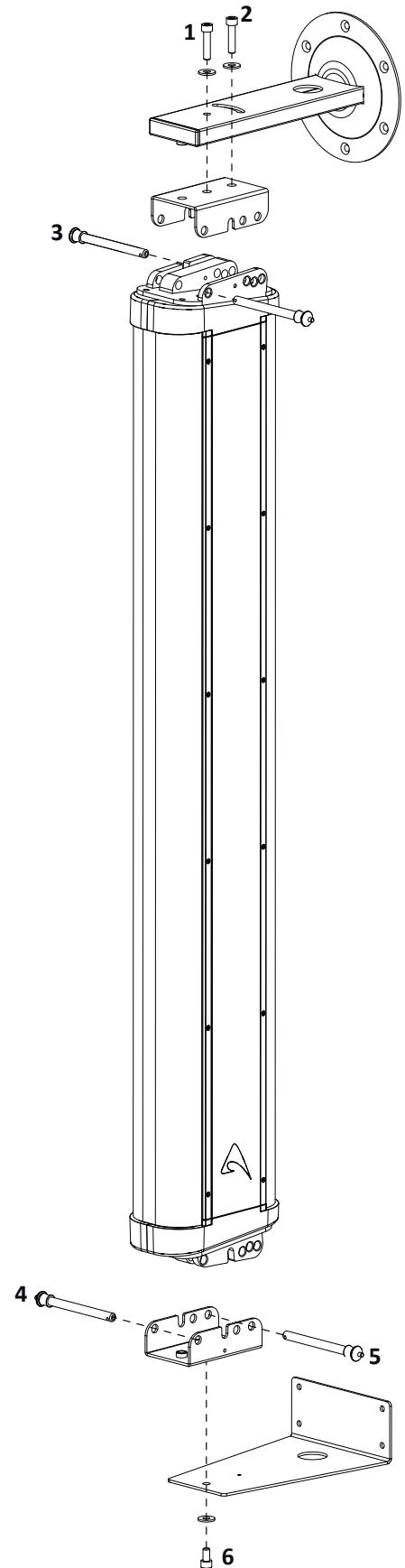



Installation using KPTAX12C flybar

Using the KPTAX12C fly bar it is possible to assemble a suspended and unobtrusive vertical array system with a variable size up to 4 elements of AX12C, or a combination of AX12C, AX6C and AX12LF without exceeding the 120Kg maximum load capacity. The loudspeakers are linked together in a column using the brackets integrated at each end of the enclosure. Each system can be set properly both acoustically and mechanically using the aiming software.

Each loudspeaker box is fixed to the next one using the two locking pins. The locking pin in the front does not require any adjustment, while the locking pin in the back is used to adjust the splay angle between two adjacent loudspeakers in the array column at 0° or 2°.

Follow the sequence in the figure for fixing the flybar to the first box. Usually this is the first step before lifting up the system. Be careful to insert properly the shackle (1)(2) and the locking pins (3)(4) in the right holes specified by the aiming software.

When lifting the system always proceed gradually step by step, paying attention to secure the flybar to the box (and the box to the other boxes) before pulling up the system: this makes easier to insert properly the locking pins.

Also when the system is released down, unlock gradually the pins.

The centre of gravity of an AX12C/AX6C/AX12LF array depends on the number of units and on the splay angle between the units, when the units are arranged to make an arc for the best coverage of the audience. Use always the aiming software to define the correct suspension pinpoint where to fix the straight shackle and the optimal splay angle between units.

Note that the ideal aiming angle often doesn't correspond to the pinpoint: there is often a little difference between ideal aiming and real aiming and its value is the Delta angle: positive delta angle can be adjusted a little using two ropes, negative delta angle are self adjusted a little because the cables weights on the back of the array. With some experience it's possible to consider preventively these required little adjustments.

During the flown set up you can connect the elements of the array to their cables. We suggest to discharge the weight of the cables from the flying pinpoint by tying them with a textile fibre rope, for this reason a ring is present at the end of the flybar that can be used to fix the cable instead of letting them hang freely: in this way the position of the array will be much more similar to the simulation produced by the software.

Wind loads

When planning an open-air event it is essential to obtain current weather and wind information. When loudspeaker arrays are flown in an open-air environment, possible wind effects must be taken into account. Wind load produces additional dynamic forces acting on the rigging components and the suspension, which may lead to a dangerous situation. If according to the forecast wind forces higher than 5 bft (29-38 Km/h) are possible, the following actions have to be taken:

- The actual on-site wind speed has to be monitored permanently. Be aware that wind speed typically increases with height above ground.
- Suspension and securing points of the array should be designed to support double the static load in order to withstand any additional dynamic forces.

WARNING!
Flying loudspeakers overhead at wind forces higher than 6 bft (39-49 Km/h) is not recommended. If the wind force exceeds 7 bft (50-61 Km/h) there is a risk of mechanical damage to the components which may lead to a dangerous situation for persons in the vicinity of the flown array.

- Stop the event and make sure that no person remains in the vicinity of the array.
- Lower and secure the array.

WARNING!
AX6C, AX12C and AX12LF must be suspended only using the flying bar KPTAX12C, with a maximum of 120Kg per flying bar.

CONDITIONS OF USE
PROEL does not accept any liability for damage caused to third parties due to improper installation, use of non-original spare parts, lack of maintenance, tampering or improper use of this product, including disregard of acceptable and applicable safety standards. PROEL strongly recommends that this loudspeaker cabinet be suspended taking into consideration all current local regulations. The product must be installed by qualified personnel. Please, contact the manufacturer for further information.

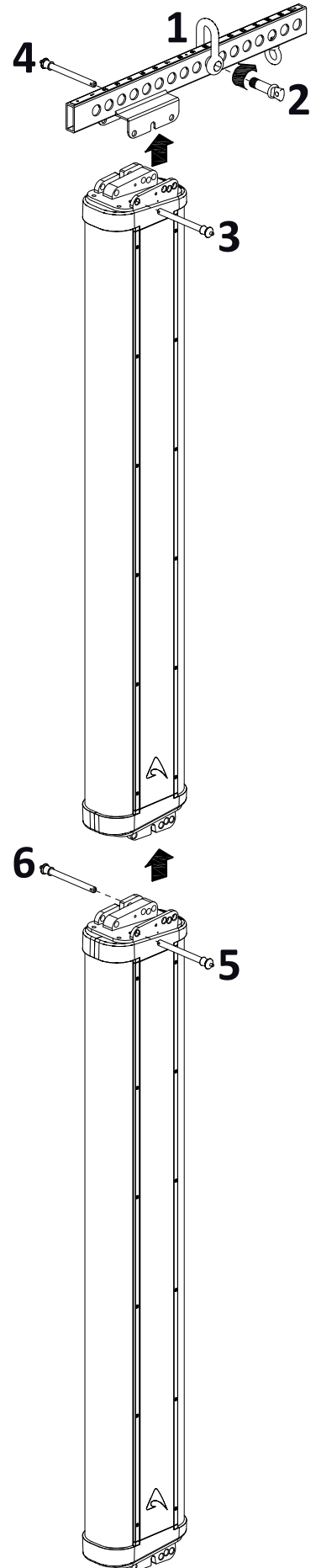



AX12C AND KPTAX12C SUSPENDING AND AIMING OPTIONS
minimum angles maximum angles

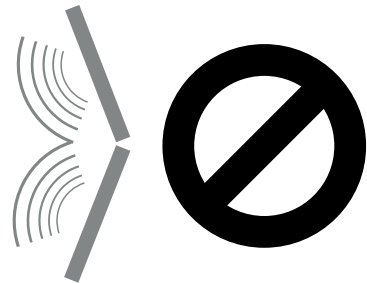
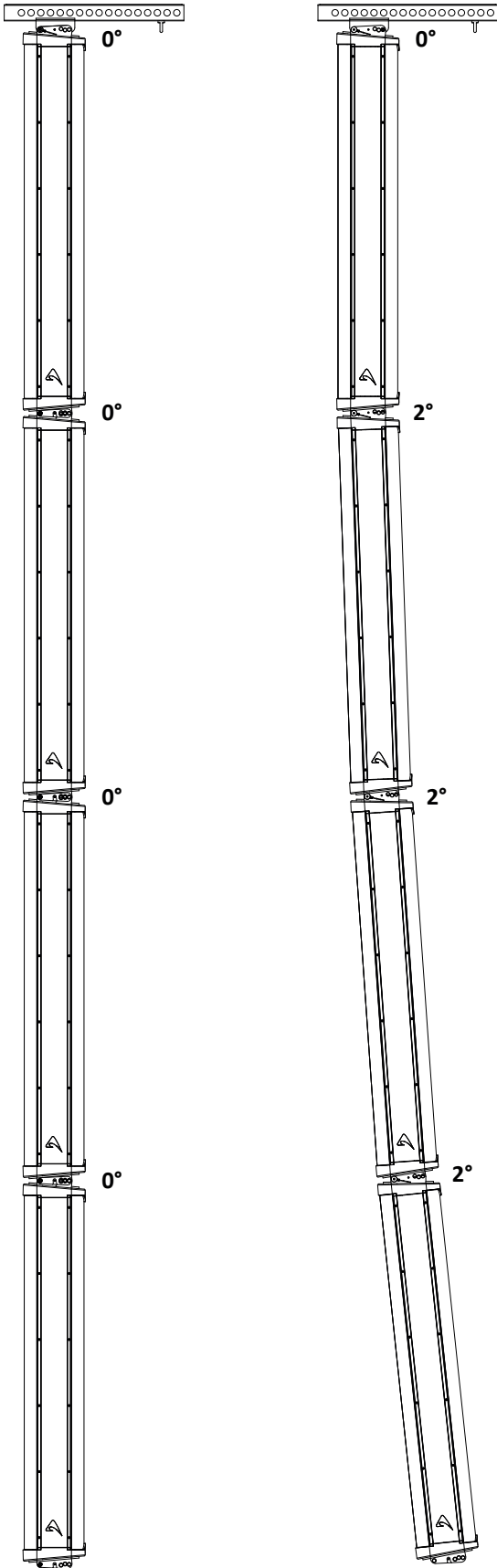

IMPORTANT:
NEVER INSTALL
2 OR MORE AX12C
AIMING THE SPEAKERS
TO EACH OTHER
WITH CLOSED ANGLES.
In other words, **NEVER** use
the 4° STACK position
between two speakers.



System Processing basic instruction

The AX12C needs an external processor to take care of the filtering, the time alignment and the speaker protection. When powered from the SW2100A amplifier output, the sub-woofer's CORE DSP takes care of all the processing and three different presets are available:

2 x AX12C this PRESET should be used for: 2x AX12C, 1x AX12C + 1x AX6C, 3x AX6C, 4x AX6C column array elements.

4 x AX12C this PRESET should be used for: 3x or 4x AX12C, 6x 7x or 8x AX6C, 3x AX12C + 1 or 2 AX6C column array elements.

1 x AX12C this PRESET should be used for: 1x AX12C, 1x AX12C + 1x AX6C, 2x AX6C column array elements.

Using the PRONET AX software, additional EQ, LEVEL and DELAY adjustment can be added to the basic presets and new presets can be saved in the SW2100A user memories.

When using the QC2.4 or QC 4.4 amplifiers to power the AX6C/AX12C, the correct presets must be loaded into the amplifier's DSP memory according to the number of columns connected.

Connection examples

SW2100A + 1 x AX12C

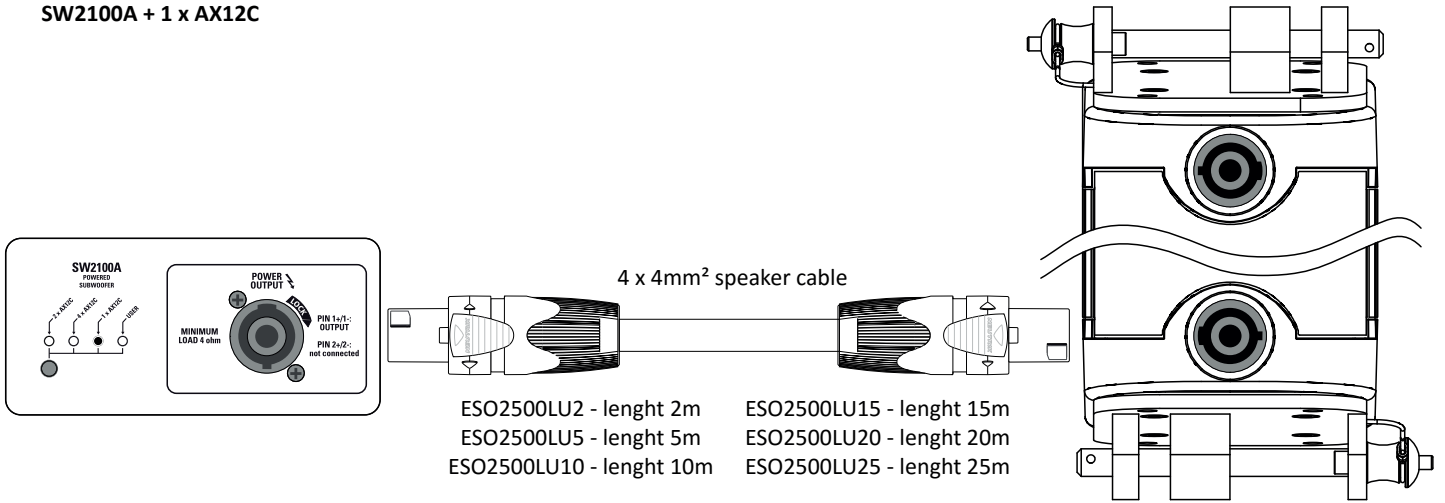

SW2100A + 2 x AX12C

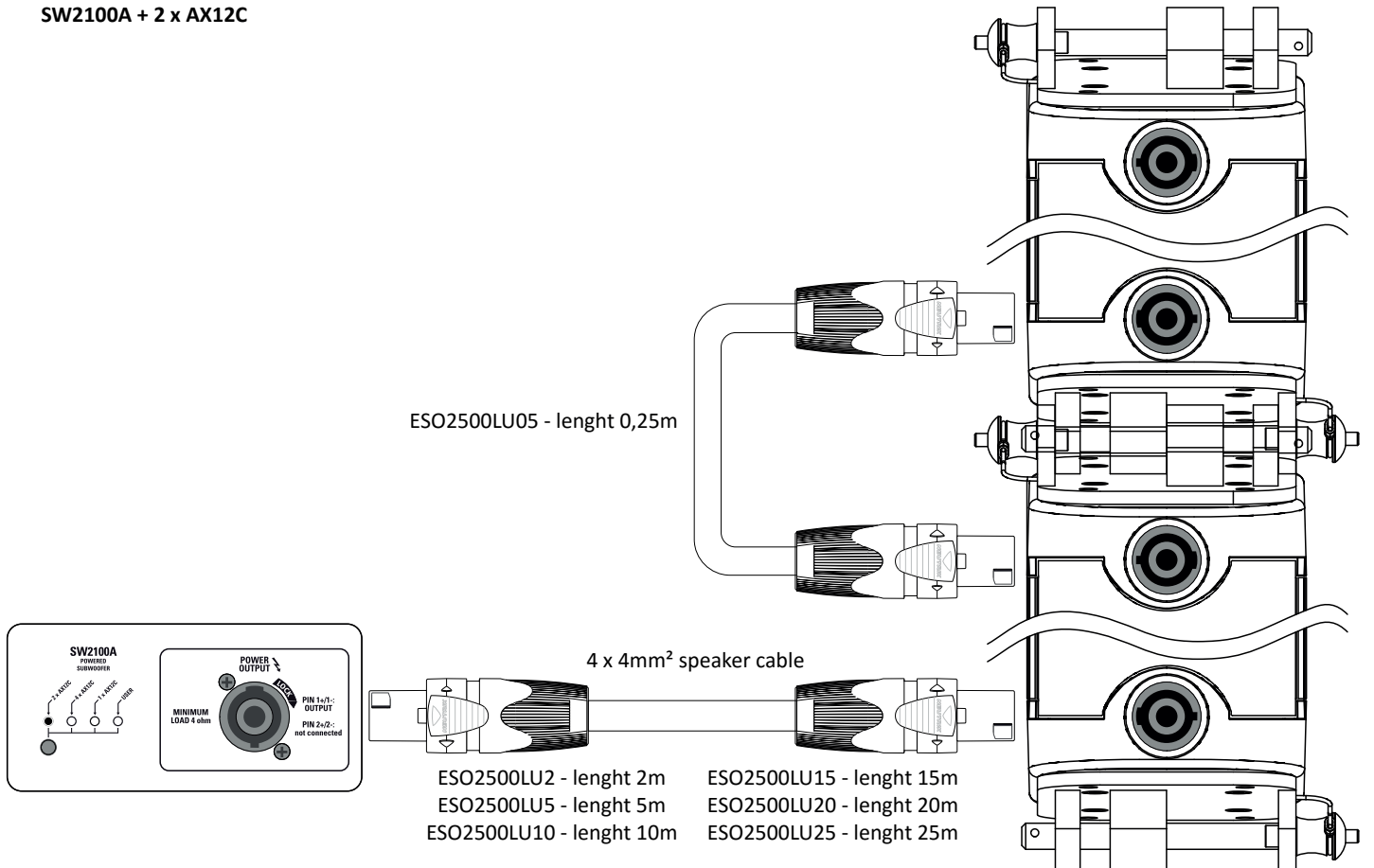



SW2100A + 4 x AX12C

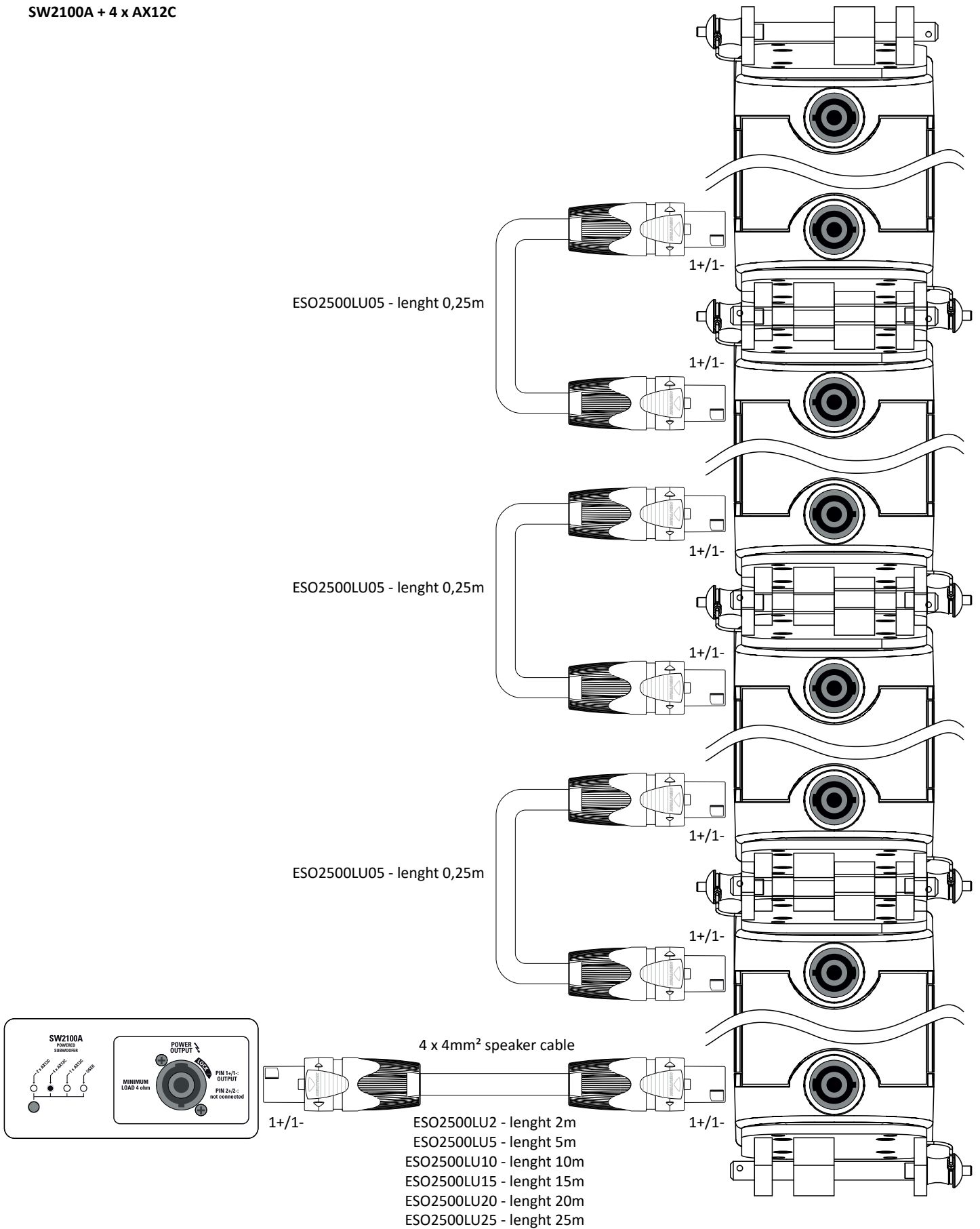





LIMITED WARRANTY

Proel warrants all materials, workmanship and proper operation of this product for a period of two years from the original date of purchase. If any defects are found in the materials or workmanship or if the product fails to function properly during the applicable warranty period, the owner should inform about these defects the dealer or the distributor, providing receipt or invoice of date of purchase and defect detailed description. This warranty does not extend to damage resulting from improper installation, misuse, neglect or abuse. Proel S.p.A. will verify damage on returned units, and when the unit has been properly used and warranty is still valid, then the unit will be replaced or repaired. Proel S.p.A. is not responsible for any "direct damage" or "indirect damage" caused by product defectiveness.

- This unit package has been submitted to ISTA 1A integrity tests. We suggest you control the unit conditions immediately after unpacking it.
- If any damage is found, immediately advise the dealer. Keep all unit packaging parts to allow inspection.
- Proel is not responsible for any damage that occurs during shipment.
- Products are sold "delivered ex warehouse" and shipment is at charge and risk of the buyer.
- Possible damages to unit should be immediately notified to forwarder. Each complaint for package tampered with should be done within eight days from product receipt.

SAFETY INSTRUCTIONS

- To reduce the risk, close supervision is necessary when the product is used near children.
- Protect the apparatus from atmospheric agents and keep it away from water, rain and high humidity places.
- This product should be site away from heat sources such as radiators, lamps and any other device that generate heat.
- This product should be located so that its location or position does not interfere with its proper ventilation and heating dissipation.
- Care should be taken so that objects and liquids do not go inside the product.
- The product should be connected to a power supply mains line only of the type described on the operating instructions or as marked on the product. Connect the apparatus to a power supply using only power cord included making always sure it is in good conditions.
- **WARNING:** The mains plug is used as disconnect device, the disconnect device shall remain readily operable.
- Do not cancel the safety feature assured by means of a polarized line plug (one blade wider than the other) or with a earth connection.
- Make sure that power supply mains line has a proper earth connection.
- Power supply cord should be unplugged from the outlet during strong thunderstorm or when left unused for a long period of time.

CE CONFORMITY

Proel products comply with directive 2014/30/UE (EMC), as stated in EN 55103-1 and EN 55103-2 standards and with directive 2014/35/UE (LVD), as stated in EN 60065 standard.

PROEL S.p.A. (World Headquarter) - Via alla Ruenia 37/43 - 64027 Sant'Omero (Te) - ITALY
Tel: +39 0861 81241 Fax: +39 0861 887862 www.axiomproaudio.com

