



# USER MANUAL

# AX6C

## High Output Column Array

### KEY FEATURES

- High Power passive portable Line Array element
- Designed for mobile and installed applications
- Fast, easy-to-use integrated suspension system
- Aluminium frame structure
- Black or white finish
- 6 x 3.5" neodymium transducers with waterproof cones
- Acoustic transmission line back loading design, resulting in clean mid-bass reproduction and natural cardioid behaviour
- Wide horizontal dispersion through Front Diffraction Waveguide (FDW)
- Line Array dispersion characteristics

### INTRODUCTION

The AX6C Line Array is a passive system equipped with six 3.5" neodymium transducers with waterproof cones, designed for portable and permanently installed applications where high power and clarity are needed. The aluminum frame box structure ensures lightweight and strength, while the shape features a back-loaded transmission line design that delivers clean mid-bass reproduction and natural cardioid behaviour. A Front Diffraction Waveguide (FDW) delivers wide horizontal dispersion, making the system flexible and adaptable to many different applications.

The AX6C line array module has been designed to be used as a stand-alone or multiple column system in fixed installations, frontfill, or under balcony applications, and for low-profile stage monitoring solutions. It can also be combined with AX12C and AX12LF columns in multiple column systems in different configurations.

The AX6C can be driven by the SW2100A processed active subwoofer or by QC Series Class D processed amplifiers. Up to eight AX6C modules (or different combinations of AX6C and AX12C) can be driven by one channel of the SW2100A subwoofer or of a QC amplifier. Different presets for different combinations are available for the built-in CORE DSP, which can be also remotely controlled using PRONET AX software.

Thanks to the elegant mechanical design the AX6C can be easily transported, while the integrated suspension system makes its deployment very fast and simple. Each unit comes with two aluminum brackets and four pins that allows multiple array elements to be easily combined either together, with the AX12C, or with the matching SW2100A subwoofer, or also in combination with the complete range of mounting hardware available, including flybar and several brackets and stands.

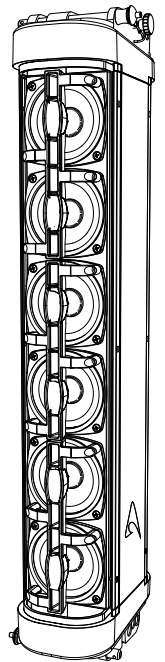

### TECHNICAL SPECIFICATION

SYSTEM		INPUT CONNECTIONS	
System's Acoustic Principle	Line Array Element Short Transmission Line Back Loading Front Diffraction Waveguide	Connector Type	Neutrik® Speakon® NL4 x 2 (1+/1- signal IN & LINK ; 2+/2- thru)
Frequency Response (±3dB)	200 Hz - 16 KHz (Processed)	<b>POWER HANDLING</b>	
Nominal Impedance	32 Ohm	Continuous AES Pink Noise Power	180 W
Minimum Impedance	25 Ohm	Program Power	360 W
Horizontal Coverage Angle	100° (-6 dB)	<b>ENCLOSURE &amp; CONSTRUCTION</b>	
Sensitivity (4V)	102 dB SPL @ 1m*	Width	107 mm (4.2")
Maximum (peak) SPL	124 dB SPL @ 1m*	Height	626 mm (24.6") - without flying system 673 mm (26.5") - with flying system
<b>TRANSDUCERS</b>		Depth	193 mm (7.6")
Type	6 x 3.5" (88mm) Neodymium magnet woofers, 1" (25mm) VC	Enclosure Material	Aluminum
Cone	Waterproof Cone	Paint	High resistance, water based paint, black or white finish
Voice Coil Type	Ventilated voice coil	Flying system	Aluminum Fast Link structure with dedicated pins
		Net Weight	6.6 kg / 13.8 lbs. (without flying system) 8.7 kg / 19.1 lbs. (with flying system)

\*measured @4 m and scaled @1 m





## MECHANICAL DRAWING

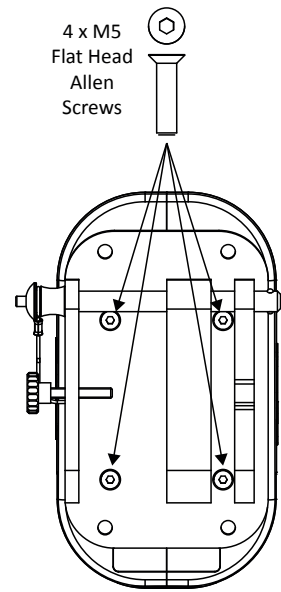
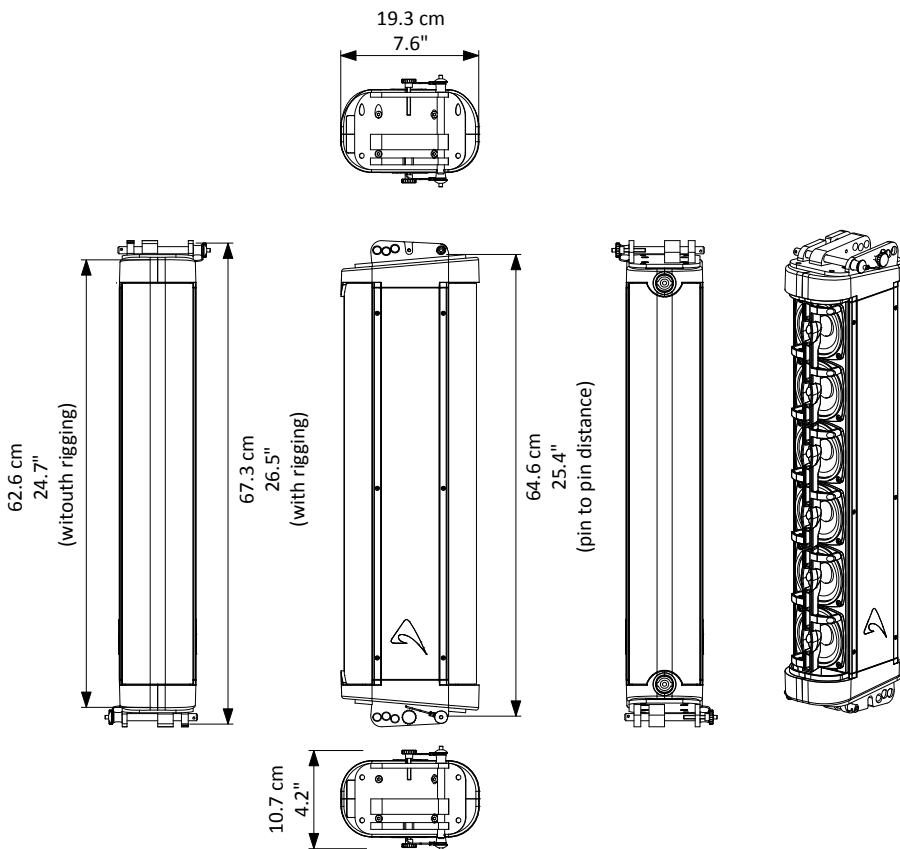

### IMPORTANT

In case you need to replace the AX6C bracket, utilize the 4 screws indicated in the figure.

In case you decide to remove the AX6C bracket (because it is not needed), put back the screws in the threaded holes as shown in the figure, in order to avoid air leakage.

## OPTIONAL ACCESSORIES

COVERAX6C	Cover / Carry Bag for AX6C
AXCASE12PT	Flight Case for 6 AX6C
ESO2500LU025	25 cm SPEAKON linking cable 4x4mm
NL4FX	Neutrik Speakon® PLUG
KPTWAX6C	Bracket for wall, ceiling, or floor mounting
KPTFAXC	Foam adapters for stage monitor or frontfill application
KPTWAX12C	Wall bracket for up to 4 units
KPTFAX12C	Floor stand
KPTPOLEAX12C	Pole adapter
DHSS10M20	Sub-Speaker ø35mm 1-1.7m Pole with Handle and M20 screw
KP210S	Sub-Speaker ø35mm 0.7-1.2m Pole with M20 screw
KPTAX12C	Flying bar
PLG716	Straight Shackle 16 mm for Fly bar

see <http://www.axiomproaudio.com> for detailed description and other available accessories.

## SPARE PARTS

NL4MP	Neutrik Speakon® panel socket
94SPI10100	Locking Pin for AX12C
98TDS3WZ22	3.5" speaker - 1" VC - 22 ohm
95MET300049	AX6C front speaker net colour black
95MET300051	AX6C rear speaker net colour black
95MET300049WH	AX6C front speaker net colour white
95MET300051WH	AX6C rear speaker net colour white





## REAR PANEL

**INPUT & LINK** - Both connectors at the top and the bottom of the AX6C can operate as input or link, to connect an appropriated processed amplifier or to link the column to a second one.

The AX6C does not include an internal passive crossover for filtering the signal, but only an internal protection that excludes the internal speaker to protect them from excessive input power. The protection should not trip with a typical music program, but only with a massive and constant power signal, like a feedback. The connections are the following:

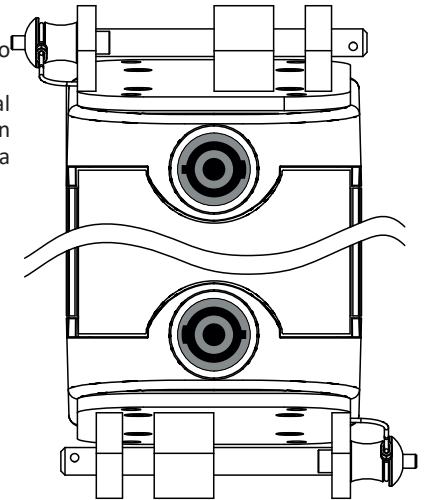

INPUT - LINK	
NL4 pin number	internal connection
1+	+ speakers (pass thru link speakon)
1-	- speakers (pass thru link speakon)
2+	+ no connection (pass thru link speakon)
2-	- no connection (pass thru link speakon)

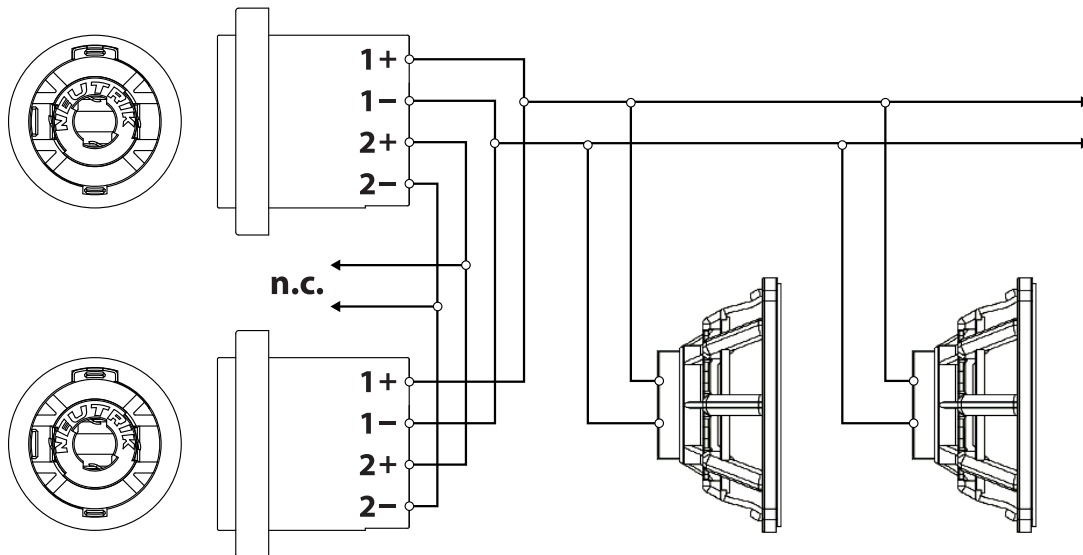

**! WARNING:** the maximum quantity of AX6C or AX12C+AX6C columns that can be linked together depends to the load capacity of the appropriate processed amplifier. When powered from the SW2100A subwoofer or from the QC2.4 suggested amplifier, a maximum of eight AX6C can be connected to each power output.

## TOOLS

This is a list of tools that can be useful to set properly a vertical column array system.

### CABLE TESTER

It is a good practice to check all cables before each installation, because even one faulty cable can compromise heavily the system performance.

### INCLINOMETER WITH LEVER

This tool can be used to verify the vertical array angle. It can be used at the top or at the bottom of the array. In this case you have to sum all splay angles, so the maximum precision is needed for aiming the vertical array, particularly for long throw applications.

### LASER DISTANCE METER

This instrument can be useful to measure the height of the vertical array and to know the distance between FOH-Subs and FOH-Array for setting the delay time.

### ACOUSTIC MEASUREMENT SYSTEM (SMAART, SATlive or similar)

These are useful to measure delays, phase and response of the system.





### PREDICTION: EASE Focus 3

To aim correctly a complete system we suggest to use always the Aiming Software - EASE Focus 3.

The EASE Focus 3 Aiming Software is a 3D Acoustic Modelling Software that serves for the configuration and modelling of Line Arrays and conventional speakers close to reality. It only considers the direct field, created by the complex addition of the sound contributions of the individual loudspeakers or array components.

The design of EASE Focus is targeted at the end user. It allows the easy and quick prediction of the array performance in a given venue. The scientific base of EASE Focus stems from EASE, the professional electro and room acoustic simulation software developed by AFMG Technologies GmbH. It is based on the EASE GLL loudspeaker data file required for its use: **AXIOM\_Column\_vX\_X.gll**. The GLL file contains the data that defines the Line Array with regard to its possible configurations as well as to its geometrical and acoustical properties.

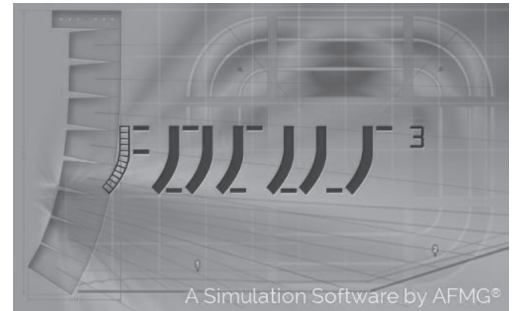

Download the EASE Focus 3 app from the AXIOM website at <http://www.axiomproaudio.com/> clicking on downloads section of the product.

Use the menu option **Edit / Import System Definition File** to import the file **AXIOM\_Column\_vX\_X.gll** from the installation Data folder, the detailed instructions to use the program are located in the menu option **Help / User's Guide**.

Note: Some windows system can require the **.NET Framework 4** that can be download from microsoft website at <http://www.microsoft.com/en-us/download/default.aspx>.



#### WARNING! CAREFULLY READ THE FOLLOWING INSTRUCTIONS AND CONDITION OF USE:

- This loudspeaker is designed exclusively for Professional audio applications. **The product must be installed by qualified personal only.**
- Proel strongly recommends that this loudspeaker cabinet be suspended taking into consideration all current National, Federal, State and Local regulations. Please contact the manufacturer for further information.
- Proel do not accept any liability for damage caused to third parties due to improper installation, lack of maintenance, tampering or improper use of this product, including disregard of acceptable and applicable safety standards.
- During assembly pay attention to the possible risk of crushing. Wear suitable protective clothing. Observe all instructions given on the rigging components and the loudspeaker cabinets. When chain hoists are in operation ensure that there is nobody directly underneath or in the vicinity of the load. Do not under any circumstances climb on the array.

### Pin locking and splay angles set up

The figure below shows how to insert correctly the locking pin and how to set up the splay angle between loudspeakers.

#### LOCKING PIN INSERTION

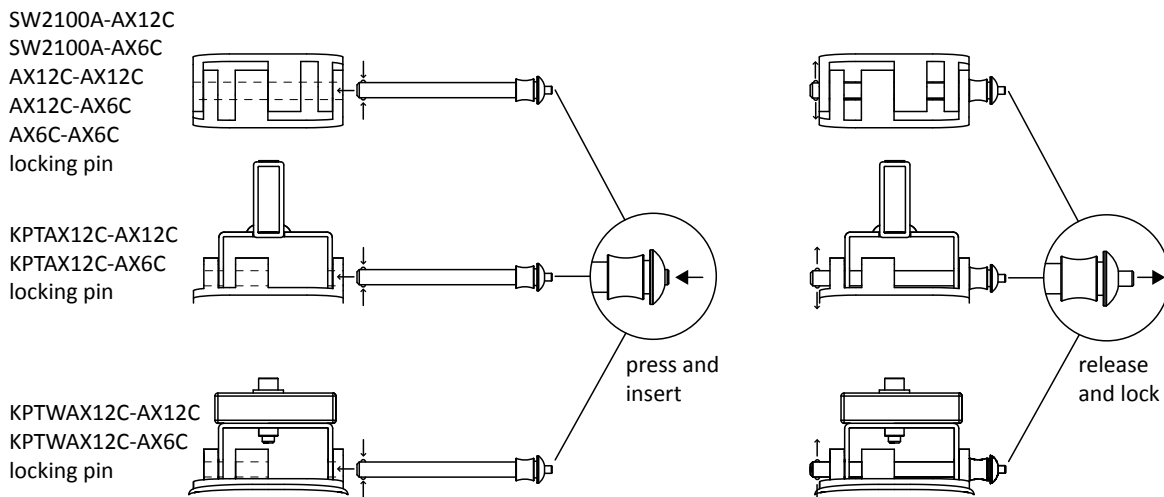

#### AX6C/AX12C SPLAY ANGLE SET UP

When connecting two speakers together or one speaker to an installation accessory, insert the pin in this hole first, also use it to rest the pin when unused.

Use these holes for the splay angle:

- 0° as no splay.
- 2° as normal splay angle to obtain a curved vertical array.
- 4° as splay angle to aim the first speaker downward (stacked only).

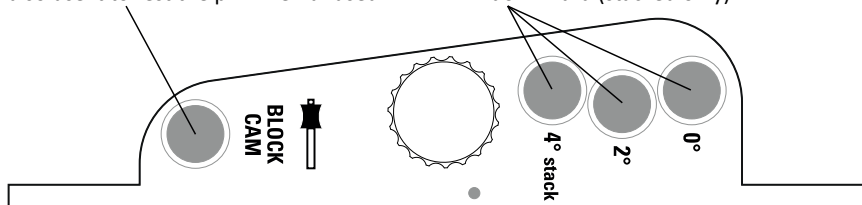



## BASIC INSTALLATION INSTRUCTIONS

### Stacked installation using SW2100A subwoofer as base

#### WARNING!



- The ground where the SW2100A is placed needs to be absolutely stable and compact.
- Adjust the feet so to put the SW2100A perfectly horizontal to ground. Use a spirit level to obtain the best results.
- Always secure ground stacked setups against movement and possible tipping over.
- A maximum of 2x AX12C or 4x AX6C or 1x AX12C + 2x AX6C speakers are allowed to be installed over a SW2100A serving as ground support.
- The optimal splay angles can be simulated using the EASE Focus 3 software.

### COLUMN STACKED ON A SW2100A



#### WARNING, DO NOT STACK MORE THAN:

- 2x AX12c or
- 4x AX6C or
- 1x AX12C + 2x AX6C.

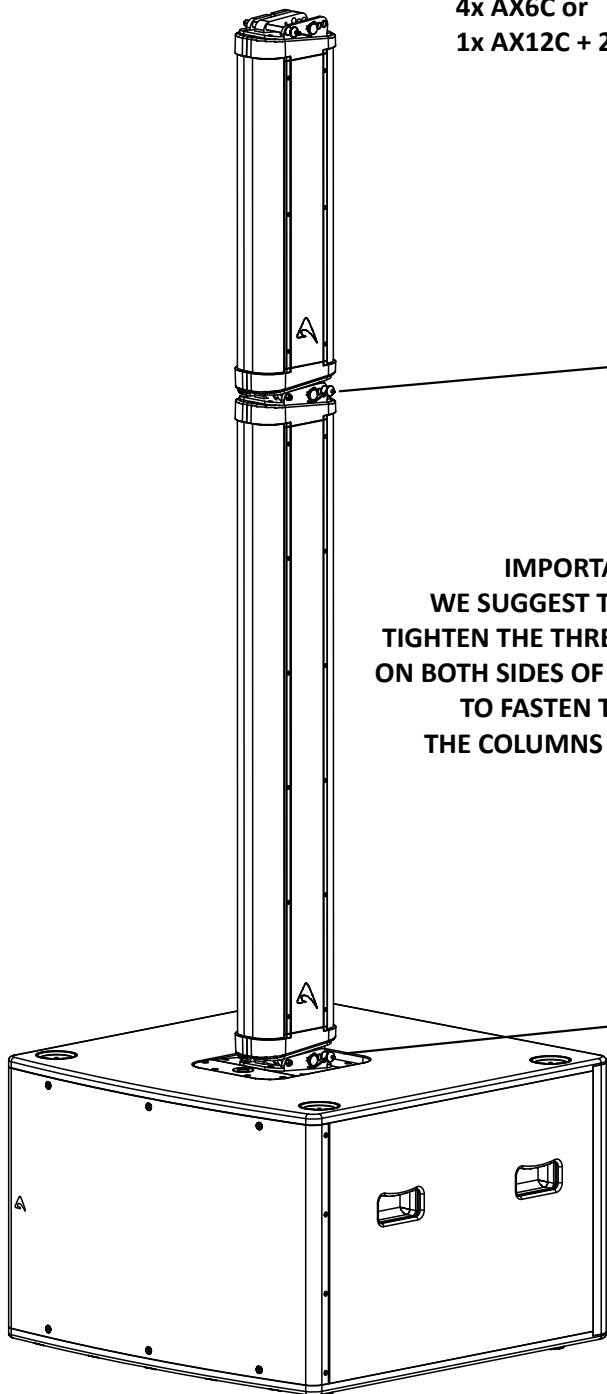

**IMPORTANT:**  
WE SUGGEST TO ALWAYS  
TIGHTEN THE THREADED KNOBS \*  
ON BOTH SIDES OF THE BRACKETS  
TO FASTEN TIGHTLY  
THE COLUMNS TOGETHER

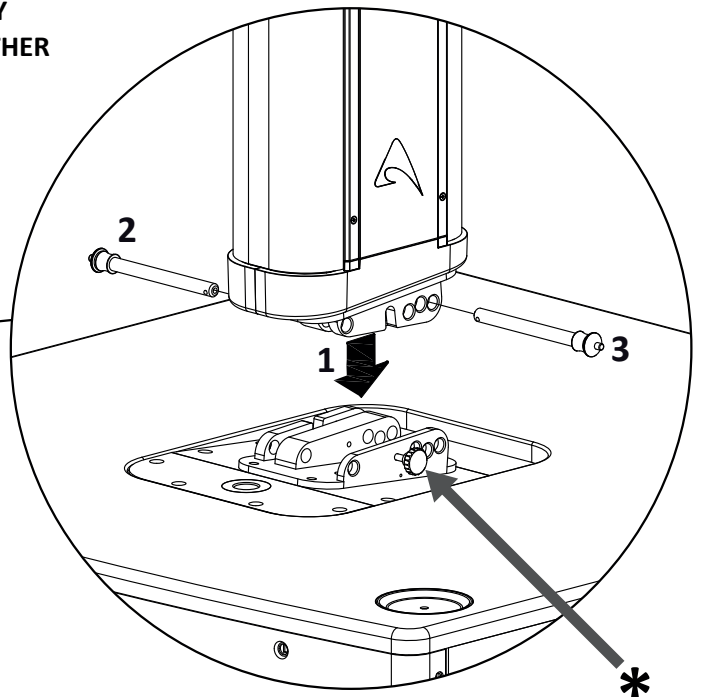
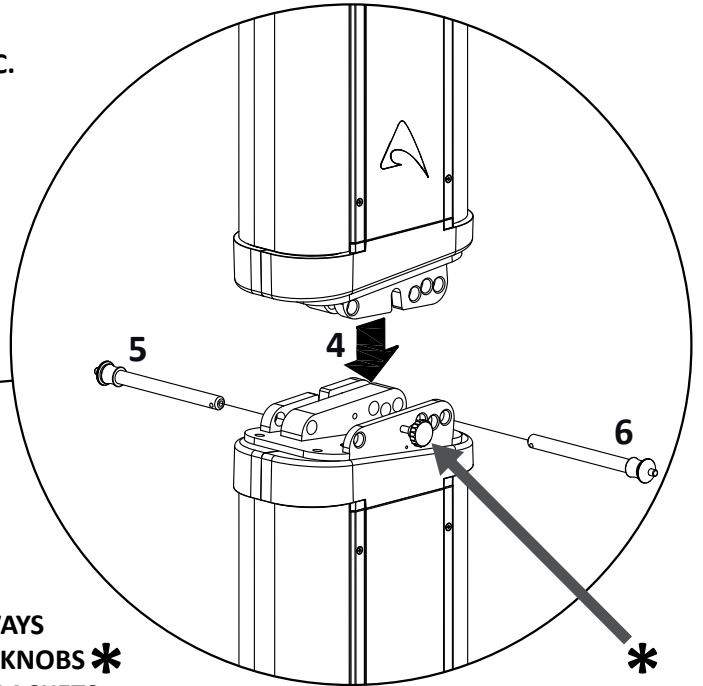



AIMING EXAMPLES OF COLUMN MOUNTED ON A SW2100A

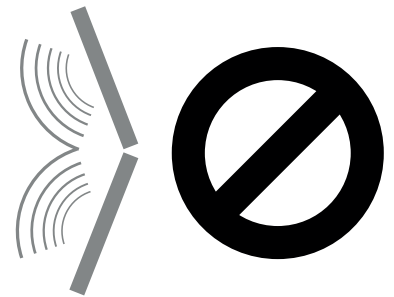
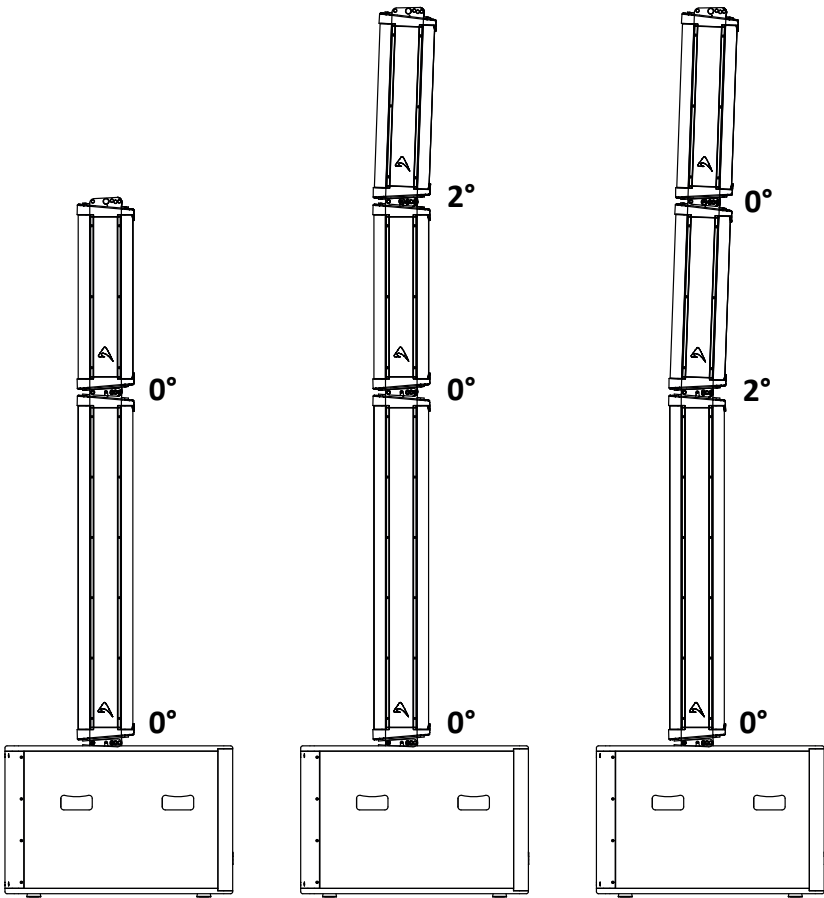

**IMPORTANT:**  
**NEVER INSTALL**  
**2 OR MORE COLUMN**  
**AIMING THE SPEAKERS**  
**TO EACH OTHER**  
**WITH CLOSED ANGLES.**  
In other words, **NEVER** use  
the **4° STACK** position  
between two speakers.

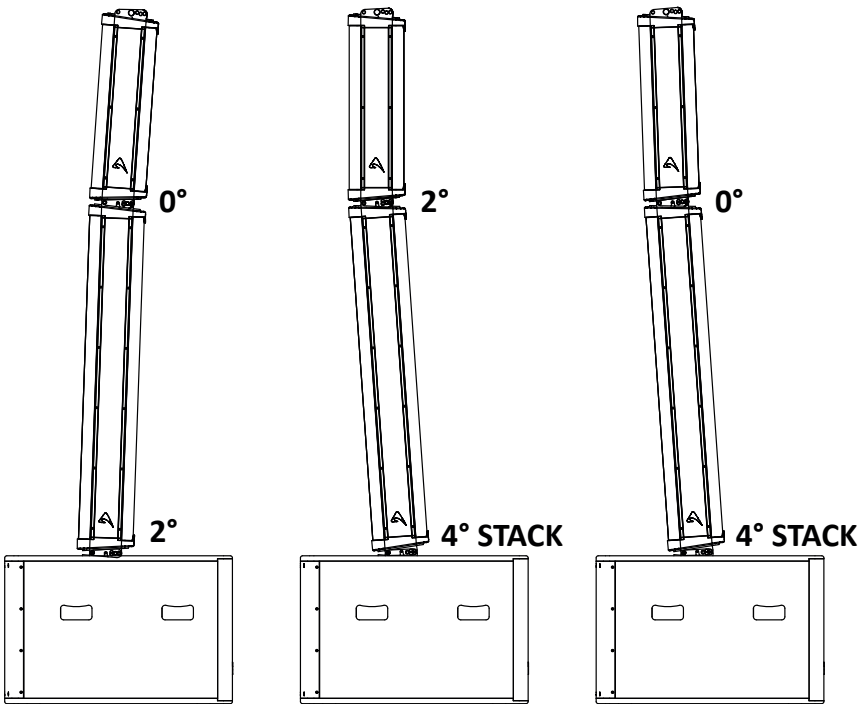



### Stacked installation using KPTFAX12C floor stand



**WARNING!**

- The ground where the KPTFAX12C floor stand is placed needs to be absolutely stable and compact.
- Adjust the feet so to put the KPTFAX12C perfectly horizontal to ground. Use a spirit level to obtain the best result.
- Always secure ground stacked setups against movement and possible tipping over.
- A maximum of 3 x AX6 or 1x AX12C + 1x AX6C speakers are allowed to be installed over a KPTFAX12C serving as ground support.
- A maximum of 2 x AX6C cabinet is allowed to be installed over a pole.
- The optimal splay angles can be simulated using the EASE Focus 3 software.

### COLUMN STACKED USING KPTFAX12C FLOOR STAND



**WARNING: DO NOT STACK MORE THAN 1x AX12C + 1x AX6C ON FLOOR STAND SET THE ANGLE ONLY TO 0° OR 2°**

**IMPORTANT: TIGHTEN STRONGLY THE THREADED KNOB \* ON BOTH SIDES TO FASTEN THE BRACKETS TOGETHER**

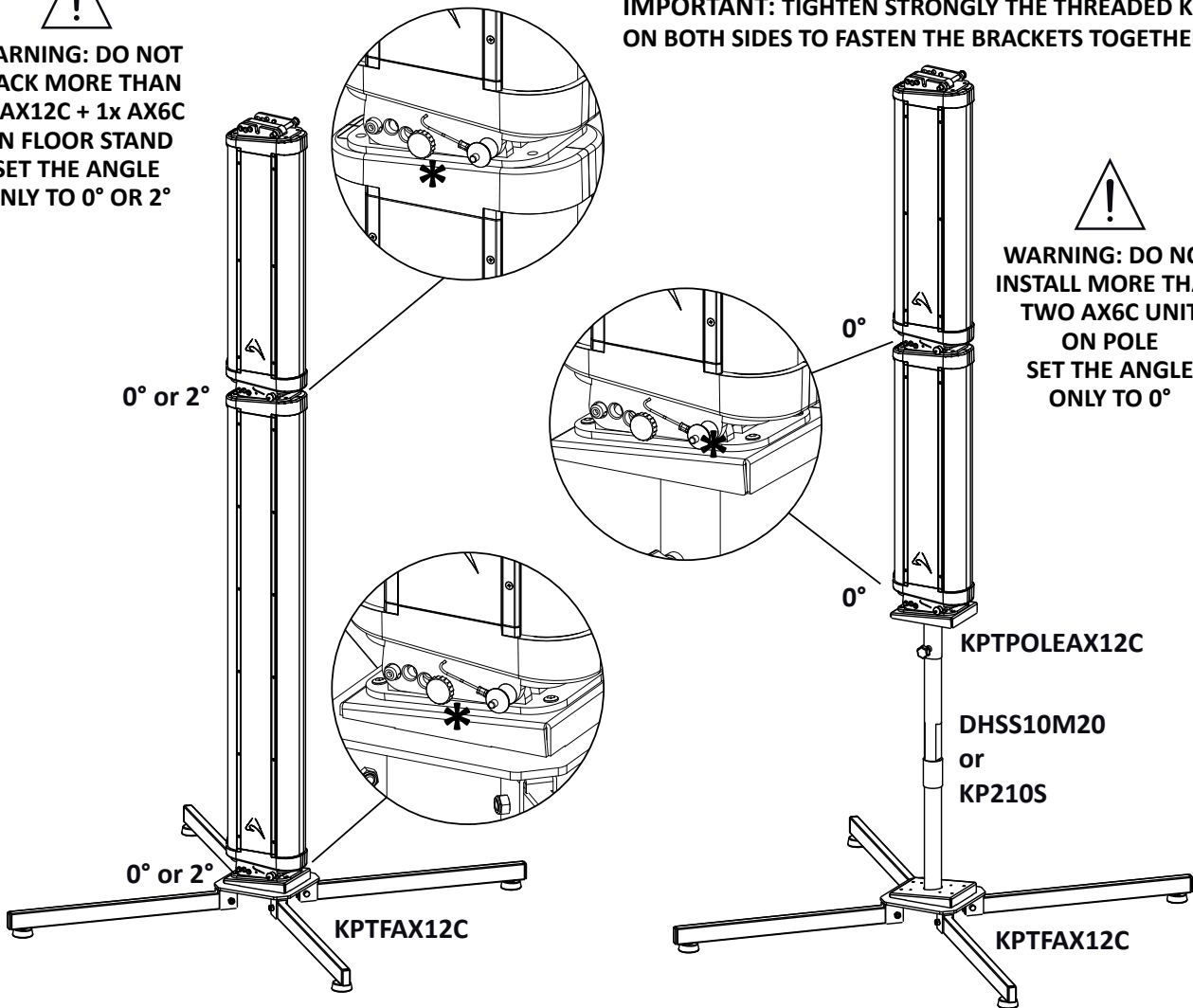

**WARNING: DO NOT INSTALL MORE THAN TWO AX6C UNIT ON POLE SET THE ANGLE ONLY TO 0°**



**IMPORTANT: NEVER INSTALL 2 OR MORE COLUMN AIMING THE SPEAKERS TO EACH OTHER WITH CLOSED ANGLES. In other words, NEVER use the 4° STACK position between two speakers.**





### Installation using KPTWAX12C wall bracket



#### WARNING!

- No hardware is supplied to install the KPTWAX12C to the walls, this hardware depends on the wall structure. Use always the best hardware available taking in consideration the whole weight of loudspeakers and accessories.
- Brackets **MUST** be installed by qualified personnel in accordance with safe installation practices.
- A maximum of 4x AX6C or 1x AX12A + 2x AX6C speakers can be installed using the KPTWAX12C wall bracket.
- When installing AX6C or combinations of AX6C + AX12C with KPTWAX12C, all the columns must be in straight position (0°). In case you need to tilt one or more columns (2°), the lower plate of KPTWAX12C must be removed.

### KPTWAX12C + AX6C AIMING OPTIONS

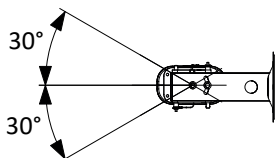
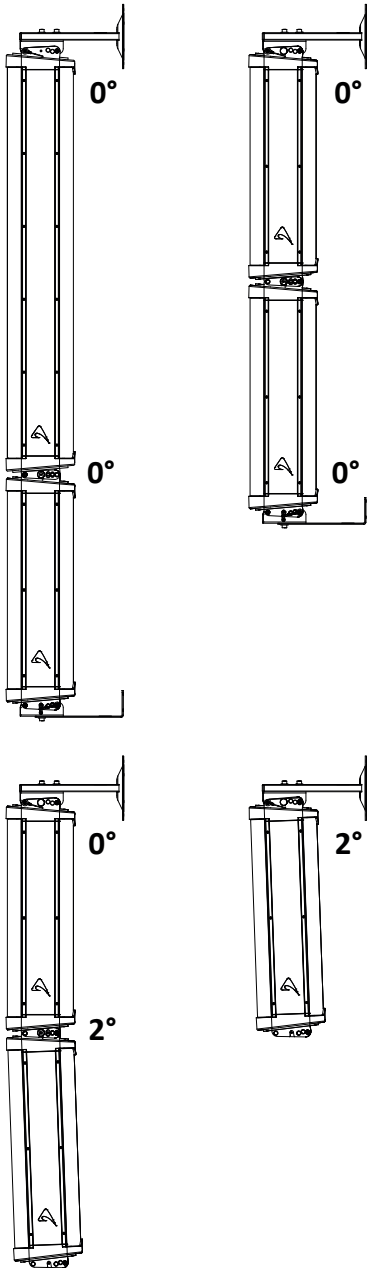

### KPTWAX12C MOUNTING OPERATIONS



**WARNING: DO NOT INSTALL MORE THAN FOUR AX6C UNITS**

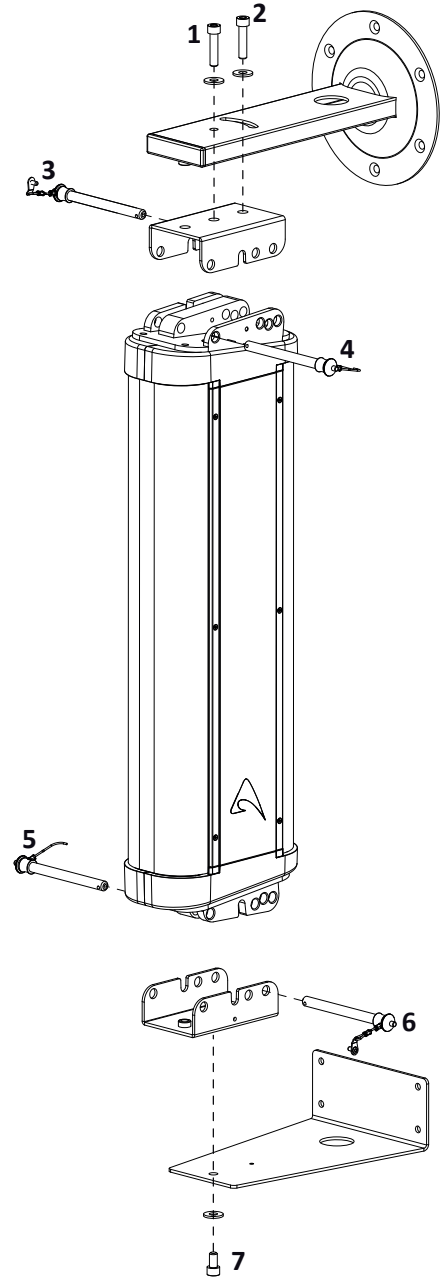





### Installation using KPTWAX6C wall bracket

The KPTWAX6C U-shaped metal bracket can be used to install AX6C in a variety of positions, including:

- on the floor as a monitor or a stage lip front fill;
- on the ceiling in under-balcony applications or for fixed installations;
- on the wall for fixed installations.

The KPTWAX6C bracket offers two different pivot points and maximum rotating angles of 40° or 50° with 10° steps.

#### WARNING!

- No hardware is supplied to install the KPTWAX6C to the walls, this hardware depends on the wall structure. Use always the best hardware available taking in consideration the whole weight of loudspeakers and accessories.
- Brackets MUST be installed by qualified personnel in accordance with safe installation practices.

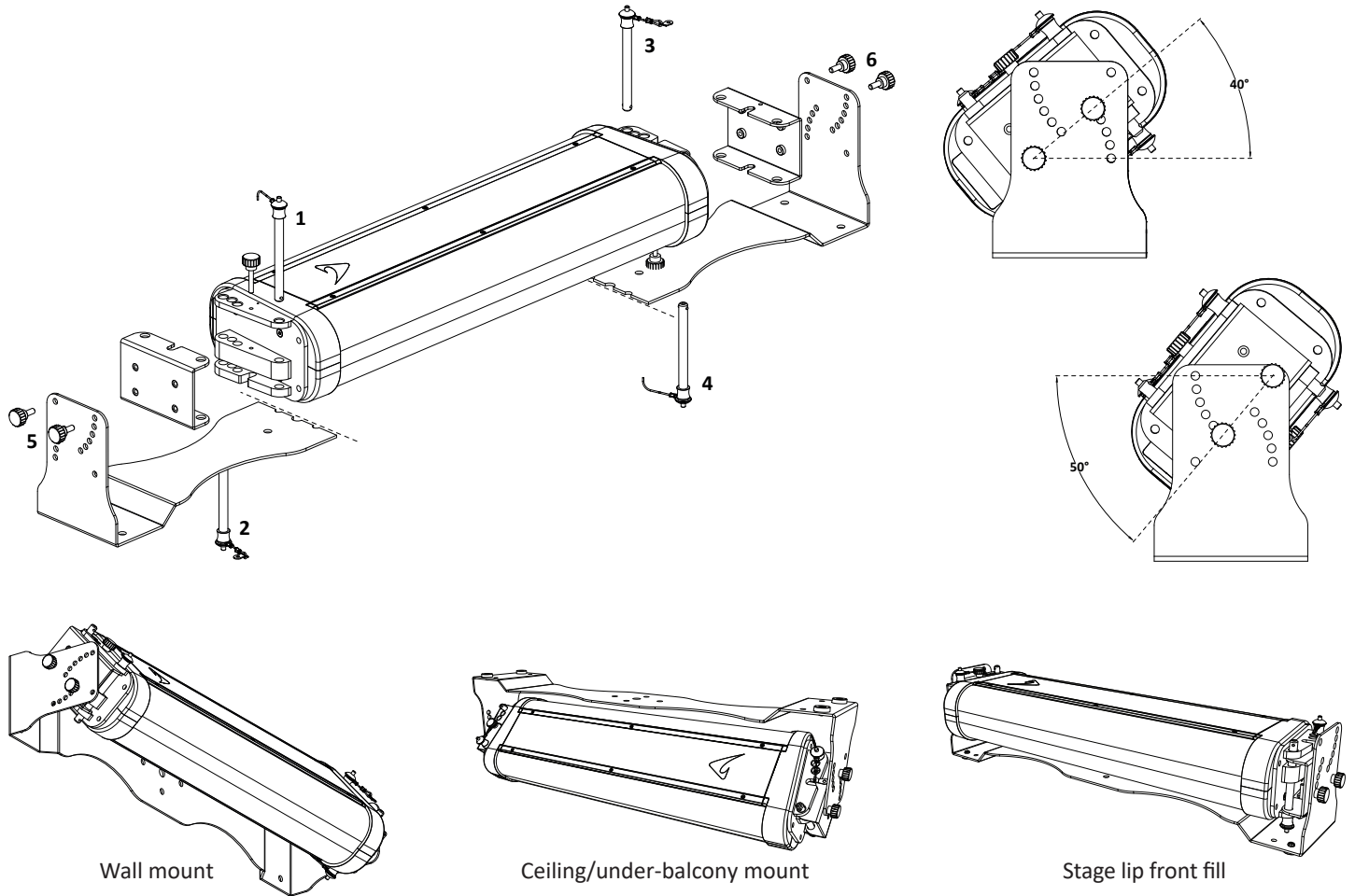

### Installation using KPTFAXC foam adapters

The KPTFAXC foam adapters, available in pairs and providing different tilt angles, are very simple and easy-to-use accessories for installing the AX6C on the floor in monitoring or front fill applications (see the KPTFAXC manual for more details).

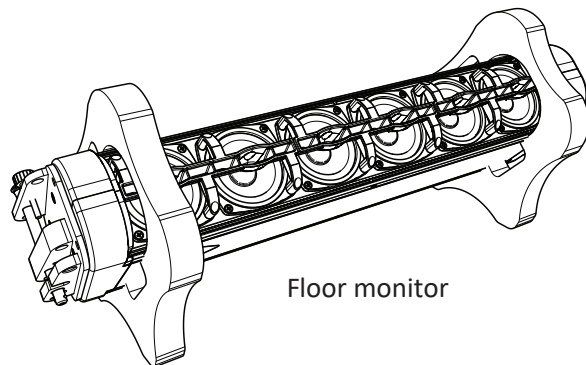



## Installation using KPTAX12C flybar

Using the **KPTAX12C** fly bar it is possible to assemble a suspended and unobtrusive vertical array system with a variable size up to 8 elements of AX6C, or a combination of AX6C and AX12C without exceeding the 120Kg maximum load capacity. The loudspeakers are linked together in a column using the brackets integrated at each end of the enclosure. Each system can be set properly both acoustically and mechanically using the aiming software.

Each loudspeaker box is fixed to the next one using the two locking pins. The locking pin in the front does not require any adjustment, while the locking pin in the back is used to adjust the splay angle between two adjacent loudspeakers in the array column at 0° or 2°.

Follow the sequence in the figure for fixing the flybar to the first box. Usually this is the first step before lifting up the system. Be careful to insert properly the shackle (1)(2) and the locking pins (3)(4) in the right holes specified by the aiming software.

When lifting the system always proceed gradually step by step, paying attention to secure the flybar to the box (and the box to the other boxes) before pulling up the system: this makes easier to insert properly the locking pins.

Also when the system is released down, unlock gradually the pins.

The centre of gravity of an AX6C/AX12C array depends on the number of units and on the splay angle between the units, when the units are arranged to make an arc for the best coverage of the audience. Use always the aiming software to define the correct suspension pinpoint where to fix the straight shackle and the optimal splay angle between units.

Note that the ideal aiming angle often doesn't correspond to the pinpoint: there is often a little difference between ideal aiming and real aiming and its value is the Delta angle: positive delta angle can be adjusted a little using two ropes, negative delta angle are self adjusted a little because the cables weights on the back of the array. Otherwise an additional KPTAX12C can be placed below the column array operating as a pullback bar.

During the flown set up you can connect the elements of the array to their cables. We suggest to discharge the weight of the cables from the flying pinpoint by tying them with a textile fibre rope, for this reason a ring is present at the end of the flybar that can be used to fix the cable instead of letting them hang freely: in this way the position of the array will be much more similar to the simulation produced by the software.

## Wind loads

When planning an open-air event it is essential to obtain current weather and wind information. When loudspeaker arrays are flown in an open-air environment, possible wind effects must be taken into account. Wind load produces additional dynamic forces acting on the rigging components and the suspension, which may lead to a dangerous situation. If according to the forecast wind forces higher than 5 bft (29-38 Km/h) are possible, the following actions have to be taken:

- The actual on-site wind speed has to be monitored permanently. Be aware that wind speed typically increases with height above ground.
- Suspension and securing points of the array should be designed to support double the static load in order to withstand any additional dynamic forces.

**WARNING!**  
**Flying loudspeakers overhead at wind forces higher than 6 bft (39-49 Km/h) is not recommended.** If the wind force exceeds 7 bft (50-61 Km/h) there is a risk of mechanical damage to the components which may lead to a dangerous situation for persons in the vicinity of the flown array.

- **Stop the event and make sure that no person remains in the vicinity of the array.**
- **Lower and secure the array.**

**WARNING!**  
**AX6C, AX12C and AX12LF must be suspended only using the flying bar KPTAX12C, with a maximum of 120Kg per flying bar.**

**CONDITIONS OF USE**  
PROEL does not accept any liability for damage caused to third parties due to improper installation, use of non-original spare parts, lack of maintenance, tampering or improper use of this product, including disregard of acceptable and applicable safety standards.  
PROEL strongly recommends that this loudspeaker cabinet be suspended taking into consideration all current local regulations. The product must be installed by qualified personnel. Please, contact the manufacturer for further information.

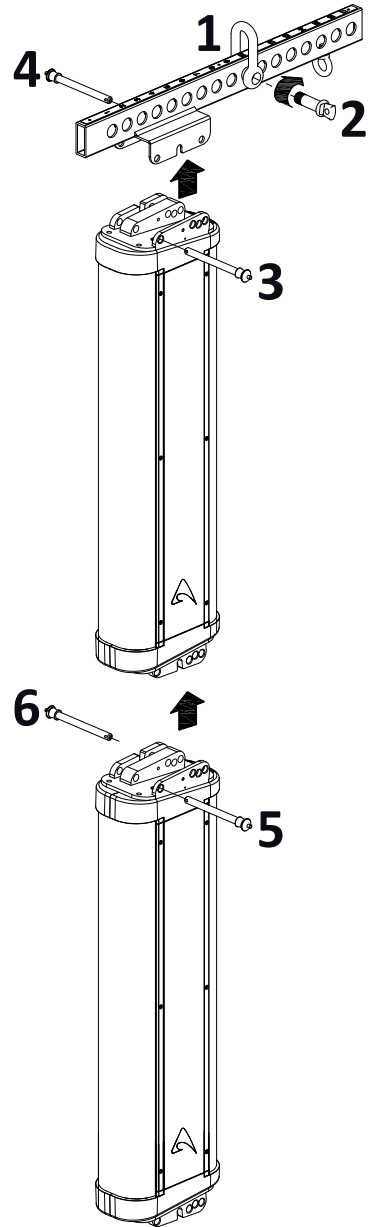



AX6C AND AX12C WITH KPTAX12C - SUSPENDING AND AIMING OPTIONS

3xAX6C + 1xAX6C

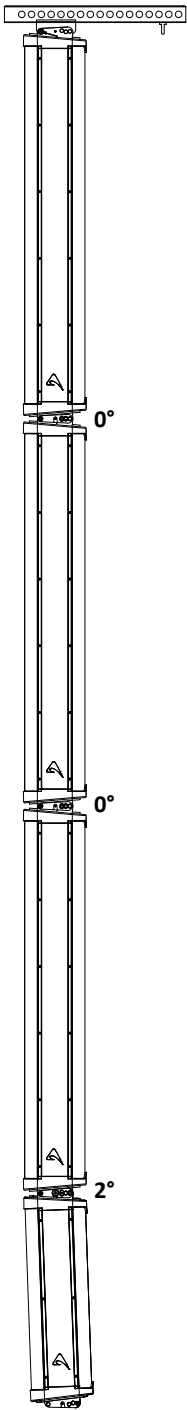

2xAX6C + 2xAX6C

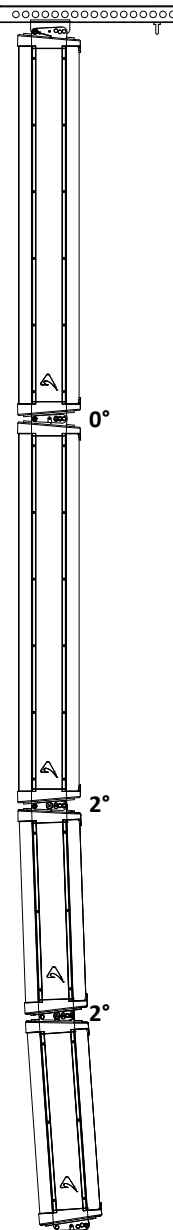

8xAX6C  
minimum angles

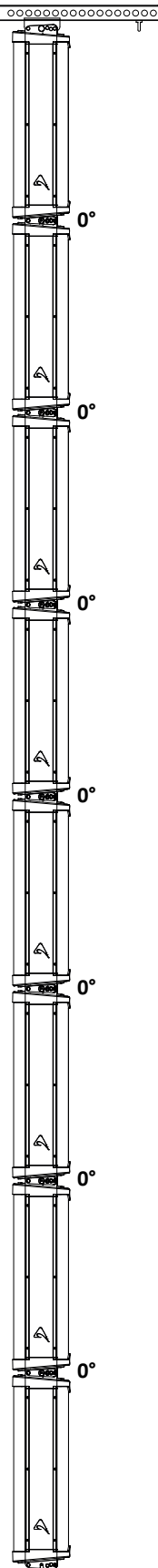

8xAX6C  
maximum angles

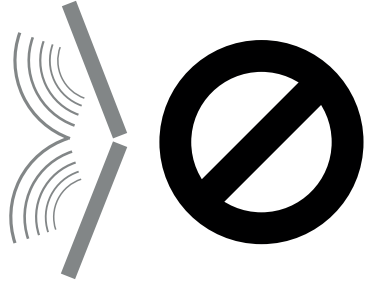
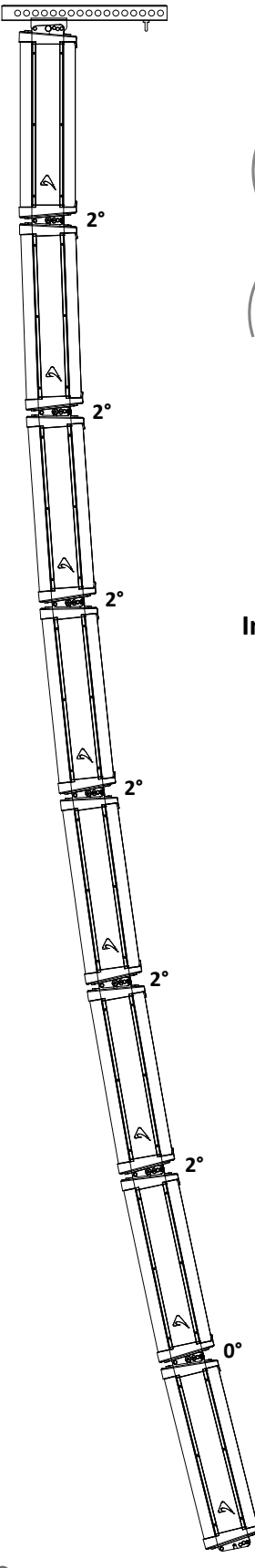

**IMPORTANT:**  
**NEVER INSTALL**  
**2 OR MORE COLUMN**  
**AIMING THE SPEAKERS**  
**TO EACH OTHER**  
**WITH CLOSED ANGLES.**  
In other words, **NEVER** use  
the 4° STACK position  
between two speakers.



### System Processing basic instruction

The AX6C can be considered like an half AX12C, so for any preset combination of AX12C you can use the same preset for AX6C simply doubling the number of AX6C speaker and for any odd combination you can choose the more similar.

The AX6C needs an external processor to take care of the filtering, the time alignment and the speaker protection. When powered from the SW2100A amplifier output, the sub-woofer's CORE DSP takes care of all the processing and three different presets are available:

**2 x AX12C** this PRESET should be used for: 2x AX12C, 1x AX12C + 1x AX6C, 3x AX6C, 4x AX6C column array elements.

**4 x AX12C** this PRESET should be used for: 3x or 4x AX12C, 6x 7x or 8x AX6C, 3x AX12C + 1 or 2 AX6C column array elements.

**1 x AX12C** this PRESET should be used for: 1x AX12C, 1x AX12C + 1x AX6C, 2x AX6C column array elements.

Using the PRONET AX software, additional EQ, LEVEL and DELAY adjustment can be added to the basic presets and new presets can be saved in the SW2100A user memories.

When using the QC2.4 or QC 4.4 amplifiers to power the AX6C/AX12C, the correct presets must be loaded into the amplifier's DSP memory according to the number of columns connected.

### Connection examples

#### SW2100A + 1x AX12C + 1x AX6C

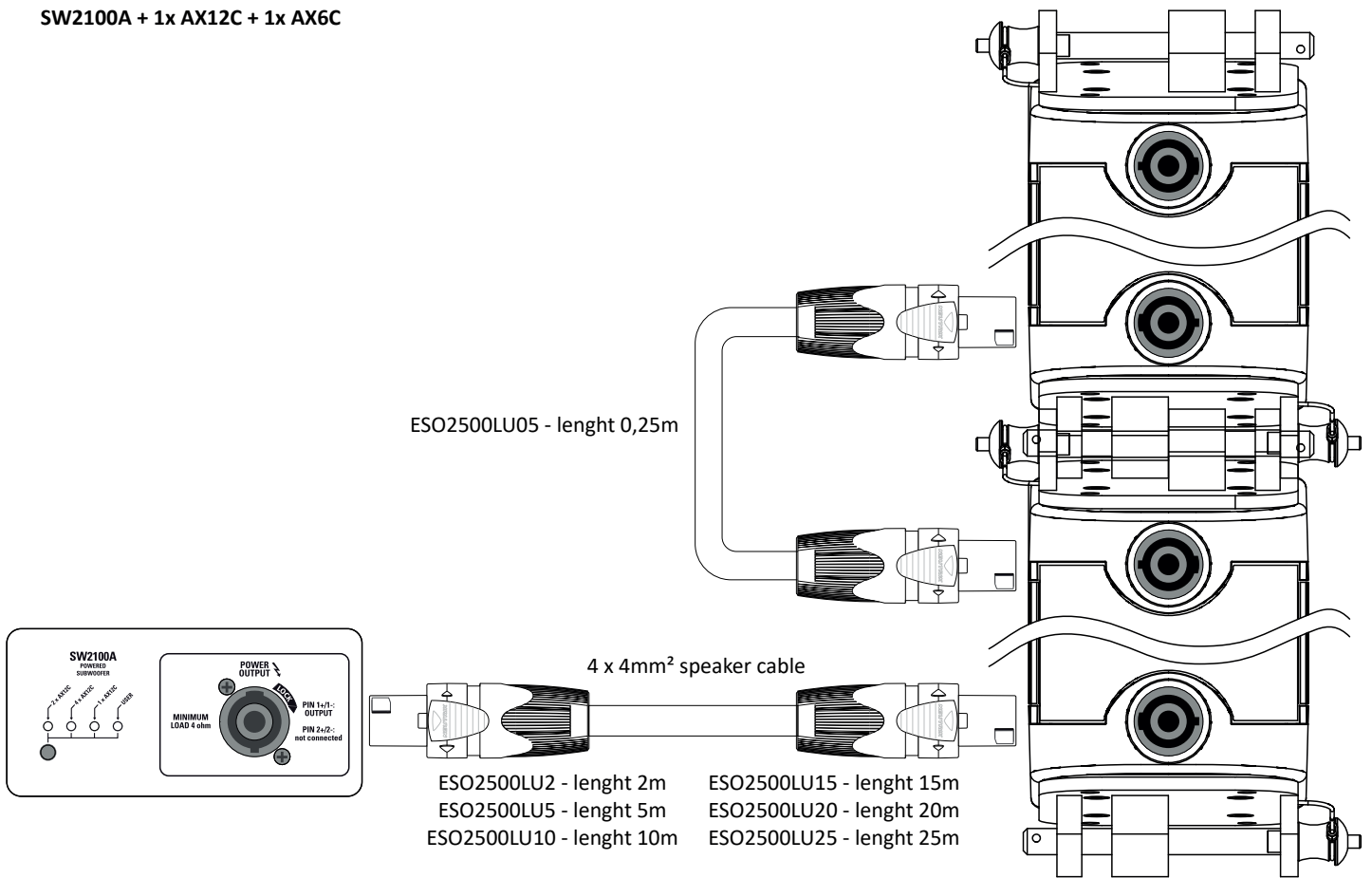



SW2100A + 3x AX6C  
or  
SW2100A + 2x AX12C + 1x AX6C  
or  
SW2100A + 1x AX12C + 2x AX6C

ESO2500LU05 - lenght 0,25m

ESO2500LU05 - lenght 0,25m

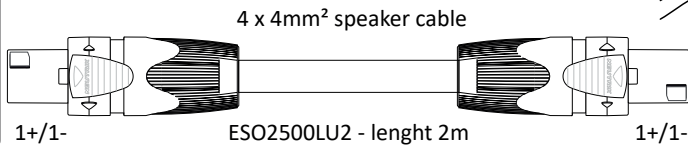
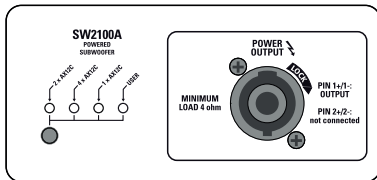

- ESO2500LU2 - lenght 2m
- ESO2500LU5 - lenght 5m
- ESO2500LU10 - lenght 10m
- ESO2500LU15 - lenght 15m
- ESO2500LU20 - lenght 20m
- ESO2500LU25 - lenght 25m

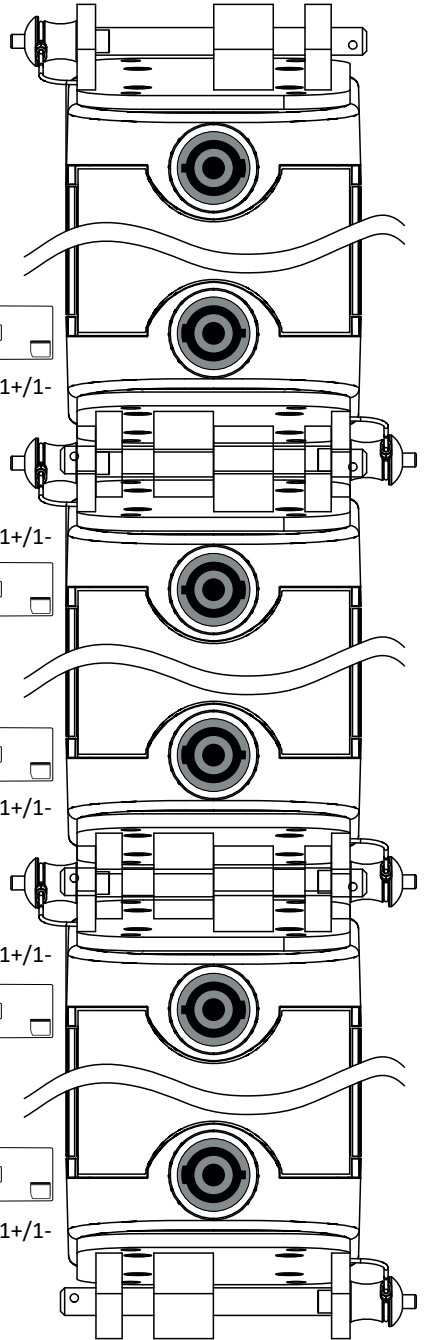



#### **LIMITED WARRANTY**

Proel warrants all materials, workmanship and proper operation of this product for a period of two years from the original date of purchase. If any defects are found in the materials or workmanship or if the product fails to function properly during the applicable warranty period, the owner should inform about these defects the dealer or the distributor, providing receipt or invoice of date of purchase and defect detailed description. This warranty does not extend to damage resulting from improper installation, misuse, neglect or abuse. Proel S.p.A. will verify damage on returned units, and when the unit has been properly used and warranty is still valid, then the unit will be replaced or repaired. Proel S.p.A. is not responsible for any "direct damage" or "indirect damage" caused by product defectiveness.

- This unit package has been submitted to ISTA 1A integrity tests. We suggest you control the unit conditions immediately after unpacking it.
- If any damage is found, immediately advise the dealer. Keep all unit packaging parts to allow inspection.
- Proel is not responsible for any damage that occurs during shipment.
- Products are sold "delivered ex warehouse" and shipment is at charge and risk of the buyer.
- Possible damages to unit should be immediately notified to forwarder. Each complaint for package tampered with should be done within eight days from product receipt.

#### **SAFETY INSTRUCTIONS**

- To reduce the risk, close supervision is necessary when the product is used near children.
- Protect the apparatus from atmospheric agents and keep it away from water, rain and high humidity places.
- This product should be site away from heat sources such as radiators, lamps and any other device that generate heat.
- This product should be located so that its location or position does not interfere with its proper ventilation and heating dissipation.
- Care should be taken so that objects and liquids do not go inside the product.
- The product should be connected to a power supply mains line only of the type described on the operating instructions or as marked on the product. Connect the apparatus to a power supply using only power cord included making always sure it is in good conditions.
- **WARNING:** The mains plug is used as disconnect device, the disconnect device shall remain readily operable.
- Do not cancel the safety feature assured by means of a polarized line plug (one blade wider than the other) or with a earth connection.
- Make sure that power supply mains line has a proper earth connection.
- Power supply cord should be unplugged from the outlet during strong thunderstorm or when left unused for a long period of time.

#### **CE CONFORMITY**

Proel products comply with directive 2014/30/UE (EMC), as stated in EN 55103-1 and EN 55103-2 standards and with directive 2014/35/UE (LVD), as stated in EN 60065 standard.

**PROEL S.p.A. (World Headquarter) - Via alla Ruenia 37/43 - 64027 Sant'Omero (Te) - ITALY**  
**Tel: +39 0861 81241 Fax: +39 0861 887862 [www.axiomproaudio.com](http://www.axiomproaudio.com)**

