



USER MANUAL

ED150P

passive point source loudspeaker

KEY FEATURES

- Near-field and mid-field sound reinforcement applications
- Asymmetric HF coverage pattern
- Rotatable HF Horn for optimal horizontal coverage
- Water-repellent treatment of LF loudspeaker
- High quality, low distortion drivers
- Audiophile-grade passive crossover network
- 35° monitor taper
- Various rigging hardware

INTRODUCTION

ED point source systems are designed for indoor and outdoor sound reinforcement applications ranging from clubs, bars and restaurants to theatres, live music venues, houses of worship and theme environments. Passive ED series loudspeaker systems are easy to set up and simple to operate.

The ED150P consists of an 15" LF drive unit and a 1.4" HF compression driver loaded by an asymmetric HF horn in a compact enclosure, designed for many multi-purpose sound reinforcement activities. The asymmetric HF coverage pattern, varying from 100° horizontal in the lower part of the horn for more effective near field coverage, and narrowing to 60° horizontal at the top of the horn for more focused coverage in the far field. The result is more accurate coverage of a typical auditorium than is possible with a fixed horizontal coverage device. The HF horn is also rotatable through 90° by simply removing four screws and realigning the horn, so that coverage can also be optimised for stage monitor use. This rotatable horn feature also makes it possible to maintain the ideal coverage pattern when the cabinet is installed in a horizontal (landscape) orientation. Its asymmetric dispersion pattern provides optimal coverage of typical rectangular venues, with wider dispersion at the front and narrower dispersion at the rear.

This versatile loudspeaker can also be used as a low profile stage monitor with its 35° tapered side, and in this situation the HF horn can be rotated to maintain the best coverage pattern for performers both near to and further away from the monitor. ED150P cabinet is an unobtrusive and compact format designed for a multitude of near field applications such as theatre under-balcony fill, stage front fill, delay speaker, bar and restaurant audio, and discreet stage monitor. A pole mount socket make this a very versatile loudspeaker in both portable and permanently installed applications.

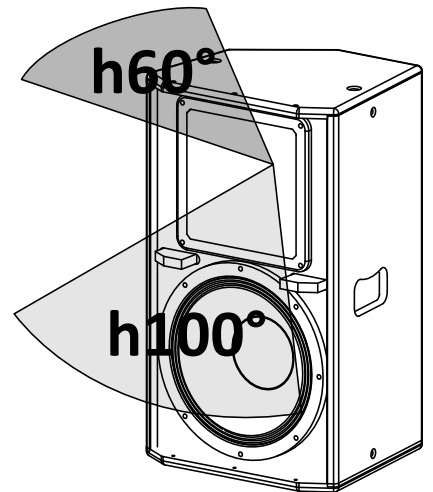

TECHNICAL SPECIFICATION

Acoustical		LF Power Compression	@ -10 dB Power (136 W) = 1 dB
System type	Point Source Loudspeaker with asymmetric HF Horn		@ -3 dB Power (680 W) = 2.8 dB
			@ 0 dB Power (1360 W) = 4 dB
		Connectors	
Low frequency transducer	15" (300 mm), 3" (75 mm) ISV aluminium voice coil, 8Ω	Connector Type	Neutrik® Speakon® NL4 x 2
		Input Wiring	Pin 1+/1- (Pin 2+/2- pass thru)
High frequency transducer	1.4" (35.5 mm) compression driver, 2.4" (60 mm) aluminium voice coil, Titanium diaphragm, 8Ω	Mechanical	
Frequency response	50 Hz – 17 kHz (-6dB)	Width	450 mm (17.7")
Sensitivity (2.83 V @ 1m, 2 Pi)	97 dB SPL	Height	765 mm (30.1")
Horizontal Coverage Angle	60 to 100° (-6 dB)	Depth	400 mm (15.8")
Vertical Coverage Angle	60°, 1KHz to 17KHz (-6dB)	Taper angle	Stage Monitor: 35° - Frontfill: 7.5°
Maximum Peak SPL @ 1m	128 dB	Construction	15mm, reinforced phenolic birch
Electrical		Paint	High resistance, water based paint
Nominal Impedance	8 Ω	Suspension system	
Minimum Impedance	6.1 Ω @ 200Hz	Suspension	M10 Rigging points
Power Handling (AES)	680 W		or dedicated metal bracket
Power Handling (prgm)	1360 W	Net Weight	30kg (66.1 lb)





MECHANICAL DRAWING

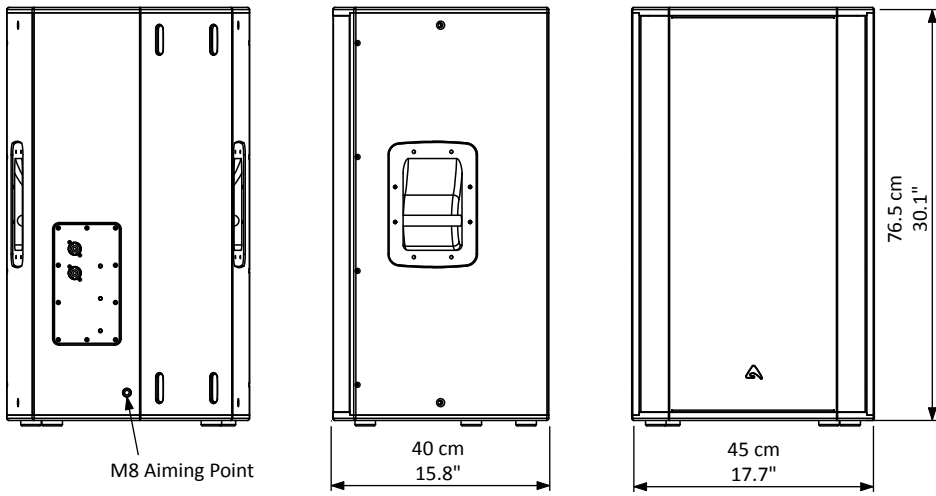

INSTRUCTION FOR ROTATING THE HORN

1) Remove the speaker grid unscrewing the twelve screws indicated below.

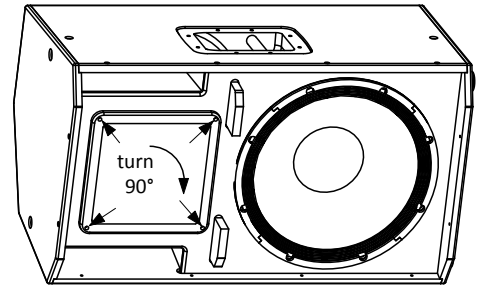
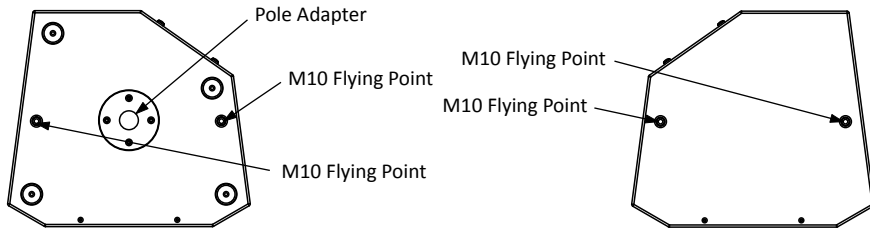
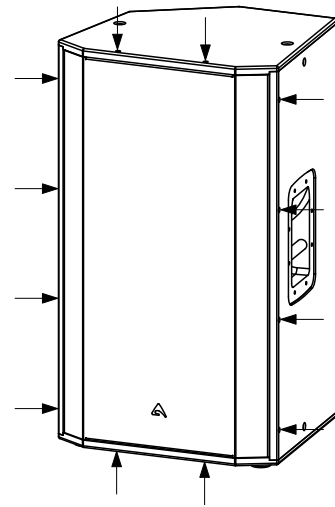

2) Unscrew the 4 screws fixing the horn and rotate the horn by 90°.

OPTIONAL ACCESSORIES

KPTED150B Wall or Truss Mounting "C" bracket.

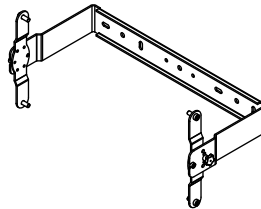

PLH300 Ø 48-51mm truss tube aluminium coupler with M12 x 50 built-in bolt and fastening nut.



NL4FX Neutrik Speakon® PLUG

see <http://www.axiomproaudio.com> for detailed description and other available accessories.

SPARE PARTS

NL4MP Neutrik Speakon® panel socket
91CR0073 ED150P Crossover PCBA
98NEOS15SW8 15" woofer - 3" VC - 8 ohm

98DRI2065 1.4" - 2.4" VC compression driver - 8 ohm
98MBN2065 titanium diaphragm for 1.4" driver





REAR PANEL

INPUT - Power input for the external amplifier. The ED150P includes a passive crossover for filtering the signal, it includes also an internal protection that limit for excessive power on the HF section and if the signal persists for a long time period it excludes the HF section. The connections are the following:

INPUT - LINK	
NL4 pin number	internal connection
1+	+
1-	-
2+	none (pass thru)
2-	none (pass thru)

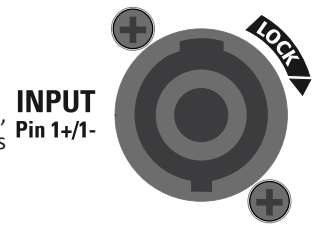

LINK - Power output in parallel with the INPUT socket for connecting the unit to another speaker. The number of ED150P cabinets that can be connected in parallel depends on the amplifier load capacity.

HORN ORIENTATION

For a correct horn orientation see the following examples:

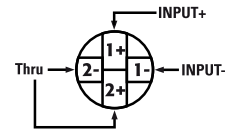

**VERTICAL POSITION
FOH CONFIGURATION**

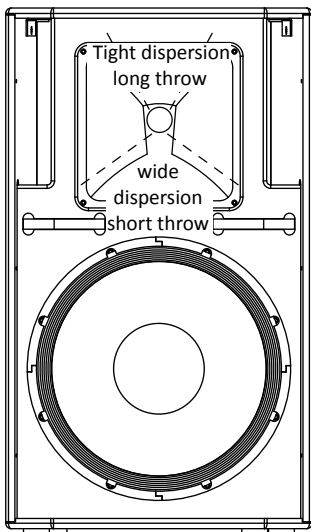

**HORIZONTAL POSITION
FOH CONFIGURATION**

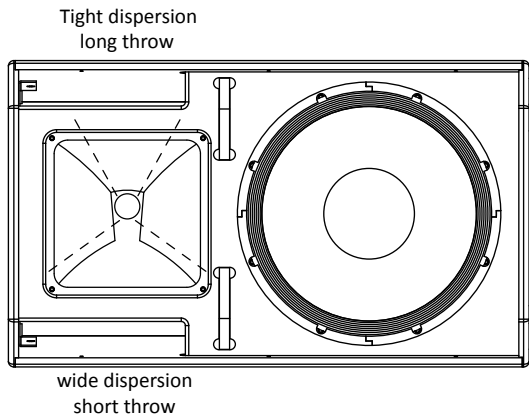

**HORIZONTAL POSITION
STAGE MONITOR CONFIGURATION**

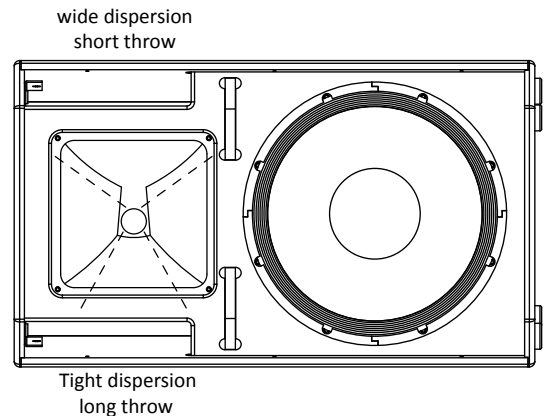

KPTED150B WALL or TRUSS MOUNTING

Using the "C" shape bracket the ED150P loudspeaker can be mounted to walls or truss combining it with two PLH300:

It allows to aim the speaker in one direction (vertical or horizontal) in 15 steps (-70°, -55°, -40°, -30°, -25°, -15°, -10°, 0°, +10°, +15°, +25°, +30°, +40°, +55°, +70°).

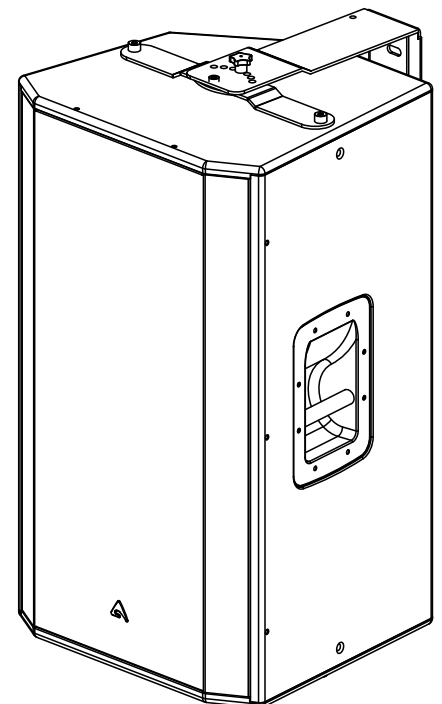



For installing the speaker using the “C” bracket follow these instructions:

- a) Install the “C” bracket to the wall or to the truss.
- b) Mount the two rotation brackets on the top and bottom of the loudspeaker using the screws (1).
- c) Carefully put the loudspeaker into the “C” bracket (2) then screw in the screws (3) to fix it to the “C” bracket.
- d) Aim the loudspeaker and tighten the screw-knobs (4) in the desired holes.
- e) Tight the screws (3).

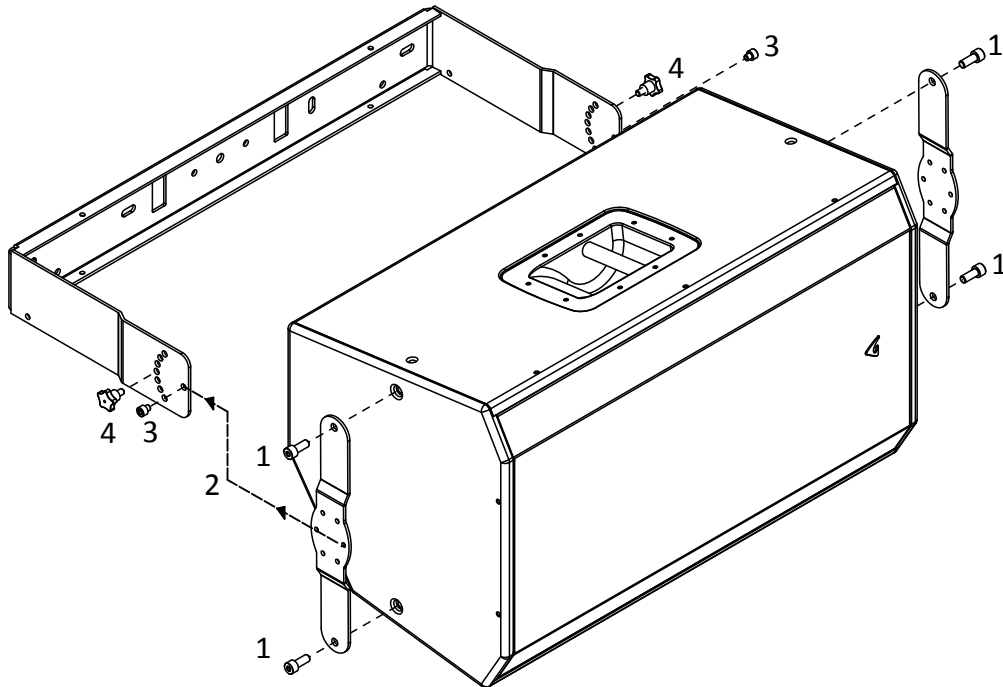

LIMITED WARRANTY

Proel warrants all materials, workmanship and proper operation of this product for a period of two years from the original date of purchase. If any defects are found in the materials or workmanship or if the product fails to function properly during the applicable warranty period, the owner should inform about these defects the dealer or the distributor, providing receipt or invoice of date of purchase and defect detailed description. This warranty does not extend to damage resulting from improper installation, misuse, neglect or abuse. Proel S.p.A. will verify damage on returned units, and when the unit has been properly used and warranty is still valid, then the unit will be replaced or repaired. Proel S.p.A. is not responsible for any “direct damage” or “indirect damage” caused by product defectiveness.

- This unit package has been submitted to ISTA 1A integrity tests. We suggest you control the unit conditions immediately after unpacking it.
- If any damage is found, immediately advise the dealer. Keep all unit packaging parts to allow inspection.
- Proel is not responsible for any damage that occurs during shipment.
- Products are sold “delivered ex warehouse” and shipment is at charge and risk of the buyer.
- Possible damages to unit should be immediately notified to forwarder. Each complaint for package tampered with should be done within eight days from product receipt.

SAFETY INSTRUCTIONS

- To reduce the risk, close supervision is necessary when the product is used near children.
- Protect the apparatus from atmospheric agents and keep it away from water, rain and high humidity places.
- This product should be site away from heat sources such as radiators, lamps and any other device that generate heat.
- This product should be located so that its location or position does not interfere with its proper ventilation and heating dissipation.
- Care should be taken so that objects and liquids do not go inside the product.
- The product should be connected to a power supply mains line only of the type described on the operating instructions or as marked on the product. Connect the apparatus to a power supply using only power cord included making always sure it is in good conditions.
- WARNING: The mains plug is used as disconnect device, the disconnect device shall remain readily operable.
- Do not cancel the safety feature assured by means of a polarized line plug (one blade wider than the other) or with a earth connection.
- Make sure that power supply mains line has a proper earth connection.
- Power supply cord should be unplugged from the outlet during strong thunderstorm or when left unused for a long period of time.

CE CONFORMITY

Proel products comply with directive EMC 2014/30/CE, as stated in EN 55103-1 and EN 55103-2 standards and with directive LVD 2014/35/CE, as stated in EN 60065 standard.

PROEL S.p.A. (World Headquarter) - Via alla Ruenia 37/43 - 64027 Sant’Omero (Te) - ITALY
Tel: +39 0861 81241 Fax: +39 0861 887862 www.axiomproaudio.com

