



**IPS-VOI
VoIP Outdoor Intercom Station**



1601 Jack McKay Blvd. • Ennis, Texas 75119 U.S.A.
Telephone: 800.876.3333 • Fax: 800.765.3435

Description

Newly designed with a faster processor and increased IP rating for weather protection, the AtlasIED SIP-enabled VoIP Outdoor Intercom is perfect for settings requiring two-way communication and secure access.

The redesigned case is more secure with increased tamper resistance. One of our most popular devices, the VoIP Outdoor Intercom has been installed in nursing care facilities, schools and universities, daycare facilities, retail establishments, highway tolls, and more, proving this device is truly a versatile, cost-efficient alternative to old analog intercoms.

Features

- IP65 rated
- Supports SRST (survivable remote site telephony)
- Streamlined case design
- PoE 802.3af enabled
- SIP compliant
- Adaptive full-duplex voice operation
- Network web management
- Network adjustable speaker volume and microphone sensitivity
- Network downloadable firmware
- Doubles as a paging speaker
- Dry relay contact for auxiliary control (controls external power)
- Peer-to-peer capable
- Door closure and tamper alert signal
- Optional security torx screws with driver kit

Applications

- Guard gates
- Banks or financial institutions
- Distribution centers
- Manufacturing warehouses
- Offices



1601 Jack McKay Blvd. • Ennis, Texas 75119 U.S.A.
Telephone: 800.876.3333 • Fax: 800.765.3435

Mounting

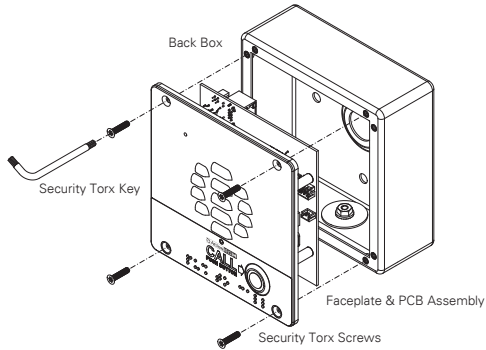

Conduit Mounting

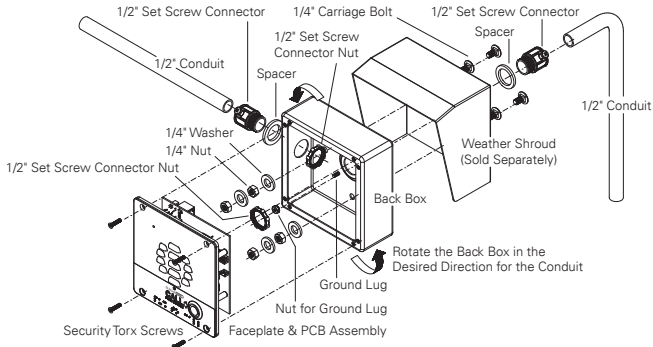

Gooseneck Mounting

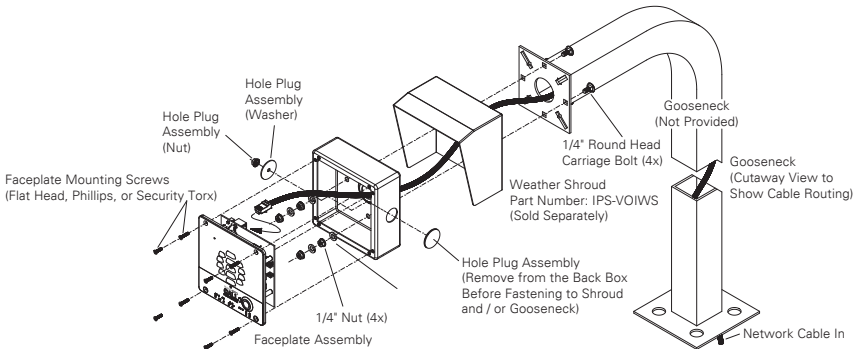

1601 Jack McKay Blvd. • Ennis, Texas 75119 U.S.A.
Telephone: 800.876.3333 • Fax: 800.765.3435

Dimensions

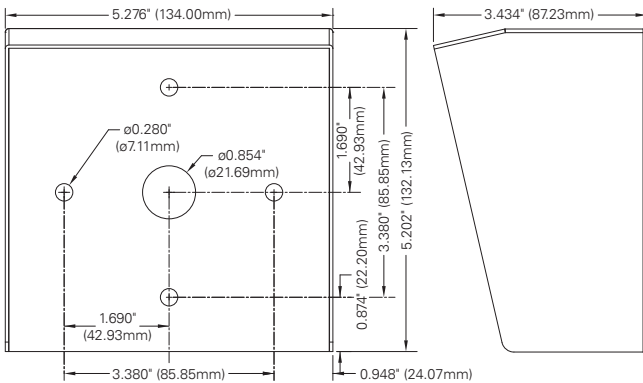
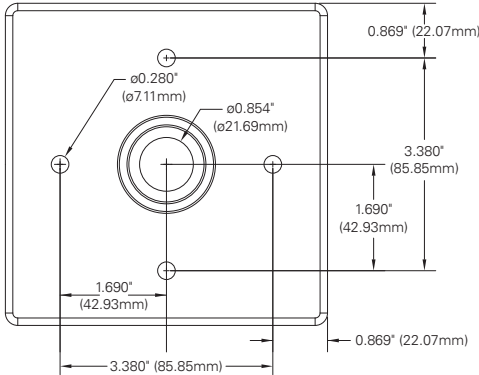
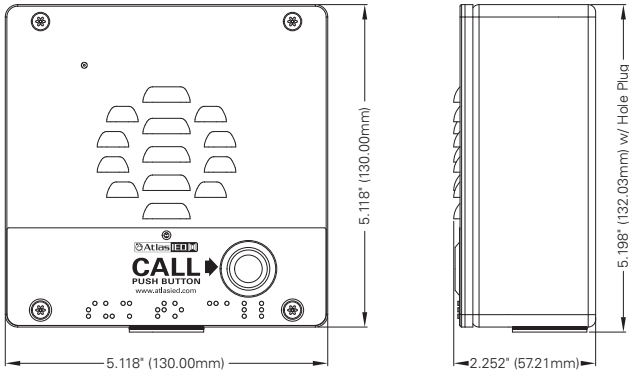

1601 Jack McKay Blvd. • Ennis, Texas 75119 U.S.A.
Telephone: 800.876.3333 • Fax: 800.765.3435

Specifications

Ethernet I/F Protocol	10/100 Mbps SIP RFC 3261 compatible
Power Input	PoE 802.3af compliant or +8 to +12VDC @ 1000mA regulated power supply
Speaker Output	1 watt peak power
On-Board Relay	1A at 30 VDC
Operating Temperature	-10° to 50° C (14° to 122° F)
Payload Types	G711, A-law and μ -law
Regulatory Compliance	FCC Class A, UL 60950
Dimensions	5.12" x 2.25" x 5.12" (130.05mm x 57.15mm x 130.04mm)
Weight	2.0 lbs. (0.90 kg)
Boxed Weight	3.0 lbs. (1.36 kg)
Warranty	1 year limited

Hardware Bag Contains:

- (1) T15 Security Torx Key
- (4) $\frac{5}{32}$ x $\frac{5}{16}$ " PH-FH Security Torx Screw
- (4) $\frac{1}{4}$ -20 x $\frac{1}{2}$ " Carriage Bolt
- (4) $\frac{1}{4}$ -20 Hex Nut
- (4) $\frac{1}{4}$ Flat Washer
- (1) Spacer Washer



1601 Jack McKay Blvd. • Ennis, Texas 75119 U.S.A.
Telephone: 800.876.3333 • Fax: 800.765.3435

Limited Warranty

All products manufactured by AtlasIED are warranted to the original dealer/installer, industrial or commercial purchaser to be free from defects in material and workmanship and to be in compliance with our published specifications, if any. This warranty shall extend from the date of purchase for a period of three years on all AtlasIED products, including SOUNDOLIER brand, INNOVATIVE ELECTRONIC DESIGNS brand, and AtlasIED brand products except as follows: one year on electronics and control systems; one year on replacement parts; and one year on Musician Series stands and related accessories. Additionally, fuses and lamps carry no warranty. AtlasIED will solely at its discretion, replace at no charge or repair free of charge defective parts or products when the product has been applied and used in accordance with our published operation and installation instructions. We will not be responsible for defects caused by improper storage, misuse (including failure to provide reasonable and necessary maintenance), accident, abnormal atmospheres, water immersion, lightning discharge, or malfunctions when products have been modified or operated in excess of rated power, altered, serviced or installed in other than a workman like manner. The original sales invoice should be retained as evidence of purchase under the terms of this warranty. All warranty returns must comply with our returns policy set forth below. When products returned to AtlasIED do not qualify for repair or replacement under our warranty, repairs may be performed at prevailing costs for material and labor unless there is included with the returned product(s) a written request for an estimate of repair costs before any nonwarranty work is performed. In the event of replacement or upon completion of repairs, return shipment will be made with the transportation charges collect.

EXCEPT TO THE EXTENT THAT APPLICABLE LAW PREVENTS THE LIMITATION OF CONSEQUENTIAL DAMAGES FOR PERSONAL INJURY, ATLASIED SHALL NOT BE LIABLE IN TORT OR CONTRACT FOR ANY DIRECT, CONSEQUENTIAL OR INCIDENTAL LOSS OR DAMAGE ARISING OUT OF THE INSTALLATION, USE OR INABILITY TO USE THE PRODUCTS. THE ABOVE WARRANTY IS IN LIEU OF ALL OTHER WARRANTIES INCLUDING BUT NOT LIMITED TO WARRANTIES OF MERCHANTABILITY AND FITNESS FOR A PARTICULAR PURPOSE.

AtlasIED does not assume, or does it authorize any other person to assume or extend on its behalf, any other warranty, obligation, or liability. This warranty gives you specific legal rights and you may have other rights which vary from state to state.

Service

Should your IPS-VOI require service, please contact the AtlasIED warranty department at 1-877-689-8055, ext. 277 or support.atlissound.com to obtain an RA number.

AtlasIED Tech Support can be reached at 1-800-876-3333 or support.atlasied.com.

Visit our website at www.AtlasIED.com to see other AtlasIED products.

©2016 Atlas Sound L.P. and Innovative Electronic Designs, LLC. All Rights Reserved. Atlas Sound is a trademark of Atlas Sound L.P. IED is a registered trademark of Innovative Electronic Designs, LLC. All other trademarks are the property of their respective owners. All specs are subject to change without notice. ATSO05372 RevB 4/16 P/N 493698



1601 Jack McKay Blvd. • Ennis, Texas 75119 U.S.A.
Telephone: 800.876.3333 • Fax: 800.765.3435