

S series S115B

Sub-woofer System



S115B is a single 15" subwoofer, bass-reflex design, full and powerful sound. Unit configuration: 1x15" 100mm high efficiency woofer. The cabinet is made of multilayer composite plywood with wear-resistant polyurea paint. U115WA is an active subwoofer.

S115B 是一款单15"超低音箱，倒相式箱体设计，具有声音丰满有力度。单元配置：1只15" 100芯低音单元。箱体采用多层复合夹板，耐磨聚脲喷涂。

CONFIGURATION

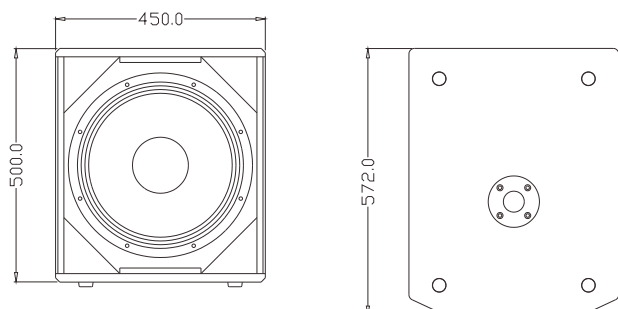

FEATURES

- High quality unit configuration, high strength plywood housing
- Bass-reflex design, full and powerful sound
- Applications: multifunction halls, high-end hotel clubs, touring

产品特点

- 高质量单元配置，高强度夹板箱体
- 倒相式设计，声音丰满且有力度

适用范围

- 多功能厅、高级酒店会所
- 流动演出



MODEL	S115B
FREQUENCY RESPONSE(-3dB)	40Hz-300Hz
DRIVERS	1×15"(385mm)/4"voice coil LF
RATED POWER	600W RMS,2400W peak
SENSITIVITY	99dB 1watt/1meter
MAXIMUM SPL	127dB continuous,133dB peak
IMPEDANCE	8 ohms nominal
INPUT CONNECTORS	2×Speakon NL4
PACKAGE SIZE	670mm×550mm×605mm
NET WEIGHT	31 kg/pc
GROSS WEIGHT	34 kg/pc