

MANUAL



ZONE4

Introduction

Zone 4 professional preamp has 4 stereo line source inputs on RCA connectors plus 3 mono mic/line balanced inputs on euroblocks. All mic inputs feature individual sensitivity, level and tone control. Mic 2 and 3 inputs have switchable phantom power. Each mic signal can be assigned to any of the 4 available zone outputs.

Microphone input 1 controls and connectors are available at the rear of the unit, featuring a balanced mic input with priority switch and zone assign preset dipswitches. If you need more flexibility and ease of installation, simply connect our APart selective paging station MICPAT-4 instead, it will override the mic 1 zone assignments.

Mic 2 and 3 inputs can be controlled and assigned via the front panel controls. In order to avoid any abuse by the end user, you can hide the microphone controls with the supplied cover plate.

Zone 1 to 4 stereo outputs can be individually configured as mono or stereo outputs and are available on RCA connectors. Every zone has its own line input selector, bass and treble tone control and music level control. Every zone also has its own microphone mix level control. Music and mic mix can be muted/unmuted manually per zone by simply pushing the level knob.

System integrators will be pleased to find a RS232 port at the back, allowing full control of the most important system parameters.

If you need to control the zones locally, you can always add a wired remote, APart model ZONE4R to any zone. Wiring is simple, using standard RJ45 connectors and CAT5 cable.

Finally there is the IR input port. This port can be used to connect our optional zone expansion unit.

Front panel

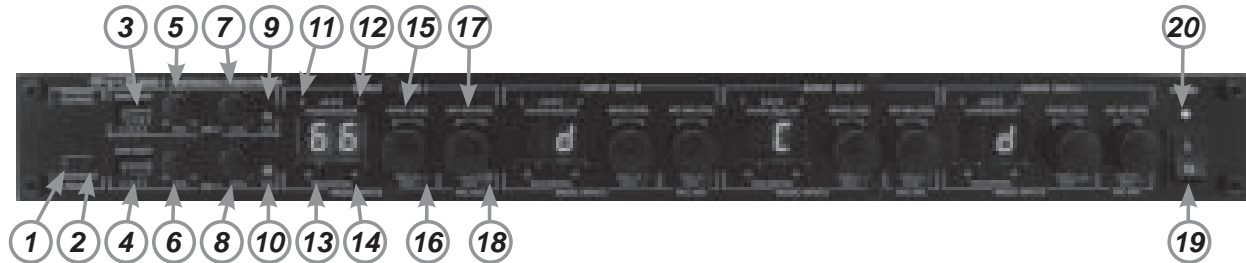

1. Disconnect paging led : this led is lit when you push the disconnect paging button '2'.
2. Disconnect paging button : push this button to disable the paging function. This can be convenient in case you want to avoid accidental paging and thus muting of the line inputs. Note that mic 2 and mic 3 are still active. The paging button(s) will not mute the music (or line signals). Mic 1 will be entirely disabled.
3. Zone assign dipswitches mic 2 : with these dipswitches you can assign the mic 2 signal to zone 1 to 4.
4. Zone assign dipswitches mic 3 : with these dipswitches you can assign the mic 3 signal to zone 1 to 4.
5. Mic 2 tone control : turn the knob to darken the tone (turn to the left) or to brighten the tone (turn to the right).
6. Mic 3 tone control : turn the knob to darken the tone (turn to the left) or to brighten the tone (turn to the right).
7. Mic 2 level control : turn the knob to the right to increase mic 2 level or to the left to reduce the level.
8. Mic 3 level control : turn the knob to the right to increase mic 3 level or to the left to reduce the level.
9. Mic signal/clip led : this led is green when a signal is present on mic 2 input and is red when the input is overloaded. Reduce the gain knob at the rear to avoid overload and distortion.
10. Mic signal/clip led : this led is green when a signal is present on mic 3 input and is red when the input is overloaded. Reduce the gain knob at the rear to avoid overload and distortion.
11. Zone 1 line input selector switches : use these switches to scroll through line input A to D. The selected input is shown in the display '12' as A, b, C, d.
12. Multifunctional 7 segment LED display : this display shows the currently selected line input. When you change the mic or music level by turning the knobs 15 or 17, the actual level is shown in the display for a few seconds.
13. Lo tone control : push the + or – buttons to increase or decrease the bass tones in zone 1. This tone control has no influence on the mic tone control and will adjust the tone on line signals only.
14. Hi tone control : push the + or – buttons to increase or decrease the high tones in zone 1. This tone control has no influence on the mic tone control and will adjust the tone on line signals only.
15. Zone 1 music level control : turn this knob to adjust the zone 1 music level. If you push this button, the music will be muted. Pushing a second time will unmute the music signal in zone 1. This is indicated by led '16'.
16. Music mute led : this led lights up when the music in zone 1 is muted by pushing the '15' knob or by activating paging.
17. Mic mix level control zone 1 : turn this knob to adjust the zone 1 mic mix level. If you push this button, the mic mix signal will be muted. Pushing a second time will unmute the mic mix signal in zone 1. This is indicated by led '18'.
18. Mic mix mute led : this led lights up when the mic mix in zone 1 is muted by pushing the '17' knob. Please note that this will not disable the paging function of the mics, in other words : if the microphone signal is muted, but when paging is activated, the music level will be muted also, unless you activate disconnect paging (button '2').
19. On/off switch : flip this switch to turn the unit on or off.
20. Power led : this led is lit when the power is on. When the unit is set to stand-by via RS232, then this led will still be lit to indicate that mains power is still present.

Rear panel

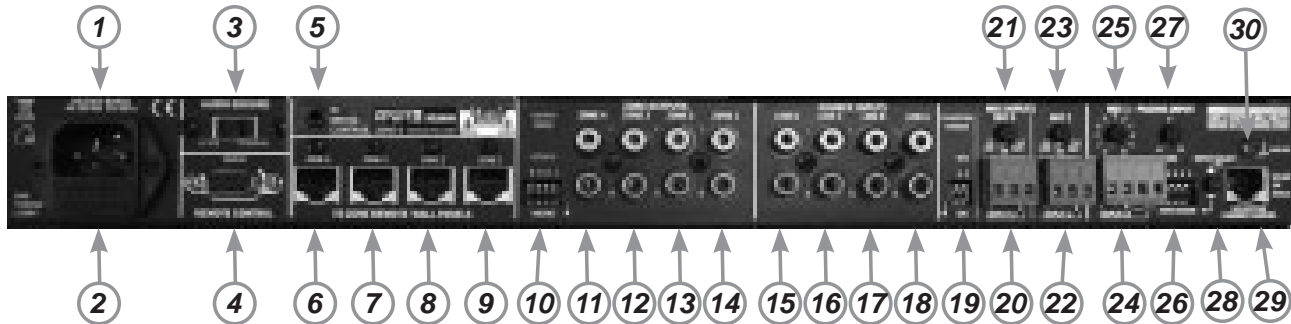

1. Mains inlet socket : connect the supplied mains cable here, the internal power supply is self adjusting and accepts AC voltages between 90 up to 260 VAC, 50 and 60 Hz.
2. Mains fuse : if the fuse blows, replace it with the same value and voltage rating, in this case : T500mA L250V.
3. Audio GND/Lift switch : use this switch to isolate the audio ground from the electrical ground. This is a handy feature to find ground loops and to avoid hum in your audio signal.
4. RS232 connector : connect your serial cable here. For details, refer to the separate serial communication section.
5. IR serial control bus : input for future remote expansion modules. Please note that no handheld infrared transmitter is available for Zone 4.
6. Zone 4 remote panels connector : connect the separately available wired remote here. This is a standard RJ45 connector for Zone 4 remote wall panels only. Never connect this to a computer or other network. Damage caused by poor or incorrect installation is excluded from the warranty.
Up to 8 pcs. ZONE4R remote panels can be connected to a single ZONE4. More than 1 panel per zone can be used. Please refer to the ZONE4R manual.
7. Same as described in 6.
8. Same as described in 6.
9. Same as described in 6.
10. Output mode selector switch : here you can configure the individual zone outputs for mono or stereo operation. In case of mono, the same 'stereo mixed into mono' signal is present on the zone left and right connectors.
11. Zone 4 output connector on cinch connectors.
12. Zone 3 output connector on cinch connectors.
13. Zone 2 output connector on cinch connectors.
14. Zone 1 output connector on cinch connectors.
15. Source D line level input on cinch connectors.
16. Source C line level input on cinch connectors.
17. Source B line level input on cinch connectors.
18. Source A line level input on cinch connectors.
19. Mic 2/3 phantom power switch.
20. Mic 3 balanced input on euroblock connector
21. Mic 3 gain control: from mic level to line level (e.g. wireless microphone receivers).

22. Mic 2 balanced input on euroblock connector
23. Mic 2 gain control: from mic level to line level (e.g. wireless microphone receivers).
24. Mic 1 balanced input connector with paging switch possibility. The paging contact can also be used for mic 2 and 3. Closing this contact mutes the music.
25. Mic 1 level control
26. Mic 1 zone assign switch.
27. Mic 1 tone control.
28. Mic 1 input selector : push the switch in/out to select the mic connector on euroblock or the MICPAT-4 selective paging station.
29. RJ45 connector for the MICPAT-4 selective paging station only. Up to 4 pcs. of MICPAT-4 can be connected to a single ZONE4. A smart bus-system arranges the Priority (busy-line). Please refer to the MICPAT4 manual.
30. Additional GND connecting screw.

Block diagram

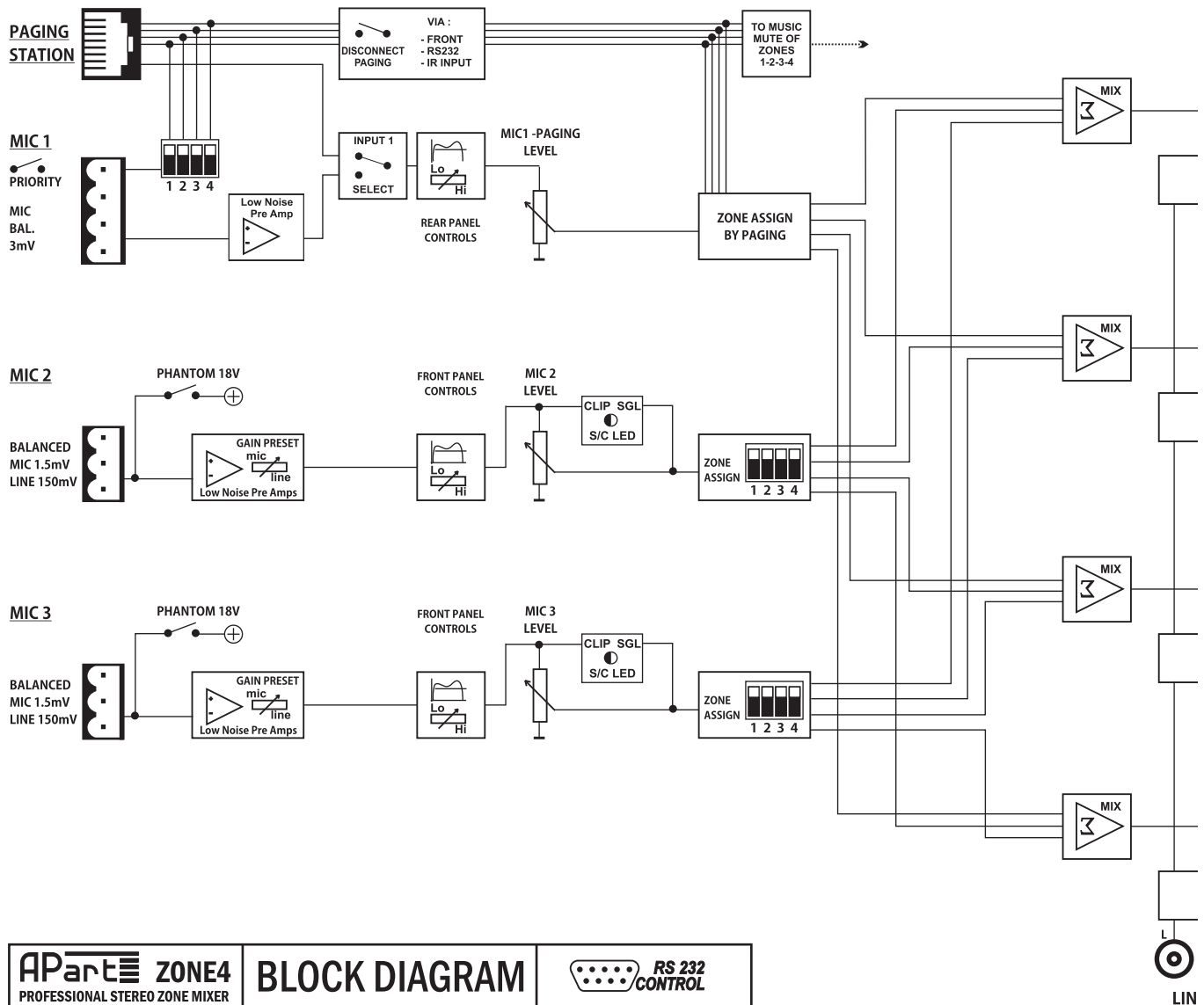

APart ZONE4 PROFESSIONAL STEREO ZONE MIXER	BLOCK DIAGRAM	
--	----------------------	--

L
LIN

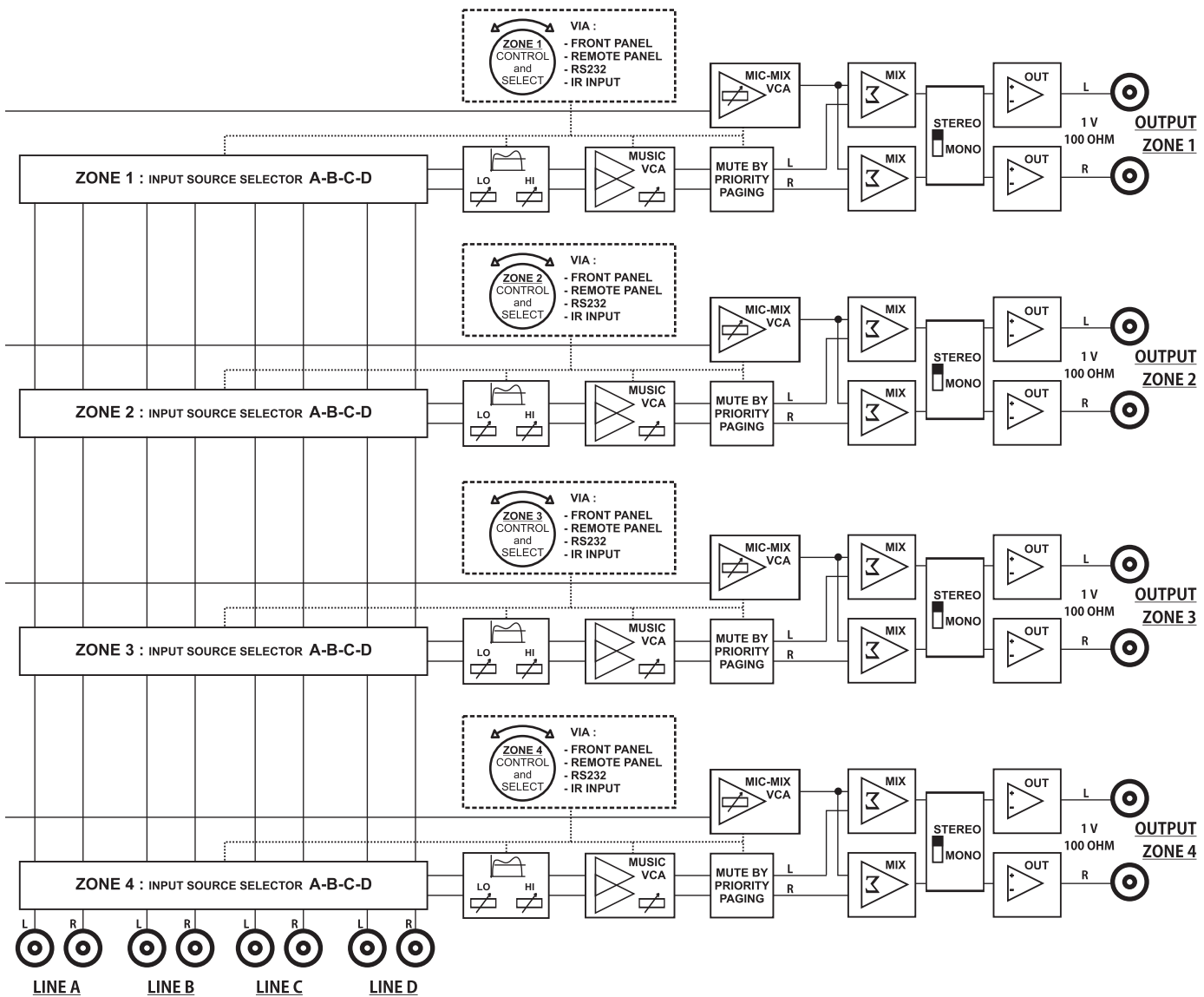

ZONE4 REMOTE CONTROL CODE

IR FUNCTIONS	ZONE	LEAD CODE	DEVICE ID CODE	DATA CODE
MUSIC VOLUME UP	ZONE 1	9MS	04FB	83
MUSIC VOLUME DOWN	ZONE 1	9MS	04FB	87
MIC VOLUME UP	ZONE 1	9MS	04FB	82
MIC VOLUME DOWN	ZONE 1	9MS	04FB	86
SELECT SOURCE A	ZONE 1	9MS	04FB	11
SELECT SOURCE B	ZONE 1	9MS	04FB	12
SELECT SOURCE C	ZONE 1	9MS	04FB	13
SELECT SOURCE D	ZONE 1	9MS	04FB	14
MUSIC VOLUME UP	ZONE 2	9MS	04FB	8B
MUSIC VOLUME DOWN	ZONE 2	9MS	04FB	8F
MIC VOLUME UP	ZONE 2	9MS	04FB	8A
MIC VOLUME DOWN	ZONE 2	9MS	04FB	8E
SELECT SOURCE A	ZONE 2	9MS	04FB	15
SELECT SOURCE B	ZONE 2	9MS	04FB	16
SELECT SOURCE C	ZONE 2	9MS	04FB	17
SELECT SOURCE D	ZONE 2	9MS	04FB	18
MUSIC VOLUME UP	ZONE 3	9MS	04FB	93
MUSIC VOLUME DOWN	ZONE 3	9MS	04FB	97
MIC VOLUME UP	ZONE 3	9MS	04FB	92
MIC VOLUME DOWN	ZONE 3	9MS	04FB	96
SELECT SOURCE A	ZONE 3	9MS	04FB	21
SELECT SOURCE B	ZONE 3	9MS	04FB	22
SELECT SOURCE C	ZONE 3	9MS	04FB	23
SELECT SOURCE D	ZONE 3	9MS	04FB	24
MUSIC VOLUME UP	ZONE 4	9MS	04FB	9B
MUSIC VOLUME DOWN	ZONE 4	9MS	04FB	9F
MIC VOLUME UP	ZONE 4	9MS	04FB	9A
MIC VOLUME DOWN	ZONE 4	9MS	04FB	9E
SELECT SOURCE A	ZONE 4	9MS	04FB	25
SELECT SOURCE B	ZONE 4	9MS	04FB	26
SELECT SOURCE C	ZONE 4	9MS	04FB	27

IR FUNCTIONS	ZONE	LEAD CODE	DEVICE ID CODE	DATA CODE
SELECT SOURCE D	ZONE 4	9MS	04FB	28
MUTE MUSIC	ZONE 1	9MS	04FB	81
UN-MUTE MUSIC	ZONE1	9MS	04FB	1A
MUTE MIC	ZONE 1	9MS	04FB	8C
UN-MUTE MIC	ZONE1	9MC	04FB	1B
MUTE MUSIC	ZONE 2	9MS	04FB	89
UN-MUTE MUSIC	ZONE 2	9MS	04FB	1C
MUTE MIC	ZONE 2	9MS	04FB	90
UN-MUTE MIC	ZONE 2	9MS	04FB	1D
MUTE MUSIC ON/OFF	ZONE 3	9MS	04FB	91
UN-MUTE MUSIC	ZONE 3	9MS	04FB	2A
MUTE MIC ON/OFF	ZONE 3	9MS	04FB	98
UN-MUTE MIC	ZONE 3	9MS	04FB	2B
MUTE MUSIC ON/OFF	ZONE 4	9MS	04FB	99
UN-MUTE MUSIC	ZONE 4	9MS	04FB	2C
MUTE MIC ON/OFF	ZONE 4	9MS	04FB	88
UN-MUTE MIC	ZONE 4	9MS	04FB	2D
DISCONNECT PAGING (ON)	-	9MS	04FB	84
CONNECT PAGING (OFF)	-	9MS	04FB	2E
SOURCE UP	ZONE 1	9MS	04FB	85
SOURCE UP	ZONE 2	9MS	04FB	8D
SOURCE UP	ZONE 3	9MS	04FB	95
SOURCE UP	ZONE 4	9MS	04FB	9D

Command structure : ZONE4 ID code → command → inverse command.

TECHNICAL SPECIFICATIONS	
OUTPUTS	
OUTPUT STEREO ZONE 1 UNBALANCED	cinch connector 0dB, 1 V, 100 Ohm
OUTPUT STEREO ZONE 2 UNBALANCED	cinch connector 0dB, 1 V, 100 Ohm
OUTPUT STEREO ZONE 3 UNBALANCED	cinch connector 0dB, 1 V, 100 Ohm
OUTPUT STEREO ZONE 4 UNBALANCED	cinch connector 0dB, 1 V, 100 Ohm
FREQUENCY RESPONSE	20Hz - 30 KHz
NOISE	> 90dB
THD	< 0,02 %
CROSSTALK	> 75 dB
MAX NOMINAL GAIN	+5 dB
MAX OUTPUT VOLTAGE	+13 dBV, 4.5 V
TONE CONTROL ZONE 1 TO 4	bass 75Hz +/-10 dB treble 10KHz +/-10 dB
LINE INPUTS	
LINE A TO D	cinch connectors L & R channel
LINE A TO D SENSITIVITY	0dBV, 1V
LINE A TO D IMPEDANCE	100 KOhm
LINE A TO D MAX INPUT LEVEL	+8 dBV
MIC/LINE INPUTS	
INPUT MIC/LINE 1	Balanced on euroblock connectors/RJ45
INPUT MIC/LINE 1 SENSITIVITY	Mic: 3mV/ -50dBv Line: 2V/ 6dBV
INPUT MIC/LINE 1 IMPEDANCE	2KOhm/11KOhm
INPUT MIC/LINE 1 MAX INPUT LEVEL	-43dBV/18dBV
INPUT MIC/LINE 2 AND 3	Balanced on euroblock connectors
INPUT MIC/LINE 2 AND 3 SENSITIVITY	trim from 1,5mV/ -56dBv to 150mV/ -16dBV
INPUT MIC/LINE 2 AND 3 IMPEDANCE	15KOhm
INPUT MIC/LINE 2 AND 3 MAX INPUT LEVEL	-38dBV to -1dBV (gain max – min)
CMRR	> 50 dB
S/N RATIO	> 65 dB @ mic level 4mV
THD	< 0,09%
PHANTOM POWER MIC 2 AND 3	18 V, individually switchable
TONE CONTROL MIC/LINE 1 TO 3	from 100Hz/+3dB,10kHz/-6dB to 100Hz/-9dB, 10KHz/+4dB
REMOTE CONTROL	
VIA RJ45 CAT-5 PER ZONE	
OPTIONAL MODELS	

TECHNICAL SPECIFICATIONS	
GENERAL	
POWER SUPPLY	90 to 260 VAC / 50-60 Hz autoranging
DIMENSIONS W X D X H	420 (484) x 190 (210) x 44 mm
SHIPPING WEIGHT	2.4 Kg
NET WEIGHT	1.6 Kg

Safety information

- Please check the carton box for any kind of damage on reception of the goods. In case of a damaged carton, please contact your dealer before opening the carton.
- **!!!! Danger !!!!** Exposure to extremely high noise levels may cause a permanent hearing loss. Individuals vary considerably to noise induced hearing loss but nearly everyone will lose some hearing if exposed to sufficiently intense noise for a sufficient amount of time. Therefore it is recommended that all persons exposed to equipment capable of producing high sound pressure levels, such as this amplifier, be protected by hearing protection while installing or operating this unit.
- Read all documentation before operating your equipment.
- Keep all documentation for future reference.
- Save the carton and packing material even if the equipment has arrived in good condition.
- Should you ever need to ship the unit, use only the original factory packing.
- Do not spill water or other liquids into or on the unit.
- Make sure power outlets conform to the power requirements listed on the back of the unit.
- Do not use the unit if the electrical power cord is frayed or broken.
- Have gain controls on amplifiers turned down during power-up to prevent speaker damage if there are high signal levels at the inputs.
- Do not connect the inputs / outputs of amplifiers or consoles to any other voltage source, such as a battery, mains source, or power supply, regardless of whether the amplifier or console is turned on or off.
- Power down & disconnect units from mains voltage before making connections.
- Do not use the unit near stoves, heat registers, radiators, or other heat producing devices.
- Do not remove the cover. Removing the cover will expose you to potentially dangerous voltages.
- In case of mal-function this device should be serviced by qualified service personnel only.



ANY SUGGESTION?

*They are well appreciated and eventually rewarded!
Send your ideas or suggestions to*

suggestions@apart-audio.com

ZONE4 is developed by

*Audioprof nv
Lanteerhofstraat 90
BE-2100 Deurne
BELGIUM*

